



# Service Manual

## Proportioning Unit

### evolution VR

Issue 3.6 21/01/22  
Ref. NR-00015-ENG

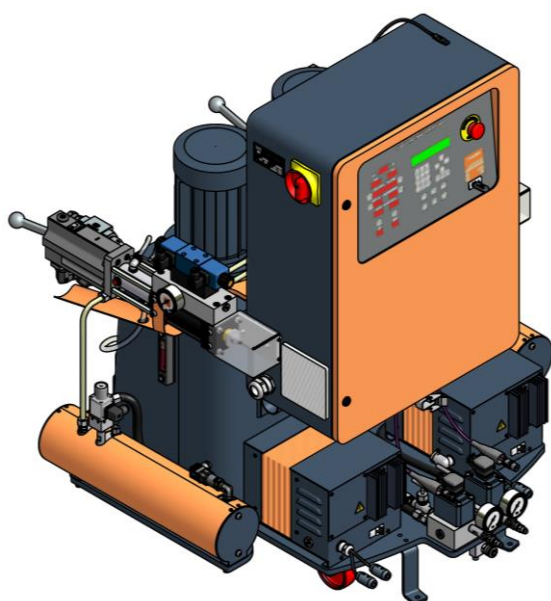

***Before installing the unit and starting it up, carefully read all the technical and safety documentation included in this manual. Pay special attention to the information to know and understand the operation and the conditions of use of the unit. All the information is aimed at enhancing User Safety and avoiding possible breakdowns derived from the incorrect use of the proportioning unit.***



## WARRANTY

HI-TECH SPRAY EQUIPMENT, S. A. (hereinafter "HI-TECH") grants this Limited Guarantee to the original buyer (hereinafter the "Client") for the unit and the original accessories given with the unit (hereinafter the "Product") against any fault in the design, materials or manufacture of the Product at the time of the first purchase by the user and for a duration of two (2) years thereafter.

If during the guarantee period and under normal conditions of use, the Product should fail to work correctly due to defects of design, material or manufacture, the authorised distributor of the country where the HI-TECH Product or technical assistance service has been purchased shall repair or replace the Product in accordance with what is established in the following:

### CONDITIONS

- a) The validity of this guarantee will be subject to the presentation of the original invoice issued by the HI-TECH authorised distributor for the sale of the Product along with the Product handed over for repair or replacement, which must show the date of purchase and the serial number. HI-TECH reserves the right to refuse to give the guarantee service when the indicated data fail to appear on the invoice or have been modified after the purchase of the Product.
- b) The repaired or replaced Product will continue to maintain the original guarantee for the time remaining until the end of the guarantee or for three (3) months from the repair date, if the remaining period of the original guarantee were shorter.
- c) This guarantee will not be applied to the faults in the Product caused by its faulty installation, the natural wear and tear of the components, any use other than that considered normal for this Product or which should fail to strictly comply with the instructions of use provided by HI-TECH; due to accident, carelessness, adjustments, alterations or modifications of the Product not authorised by HI-TECH or due to the use of accessories, heating devices, pumping equipment and/or dispensers that have not been approved or manufactured by HI-TECH.
- d) The guarantee applicable to the components and accessories forming part of the Product and which have not been made by HI-TECH will be limited to the guarantee offered by the original manufacturer thereof.

**HI-TECH WILL NOT RECOGNISE ANY EXPRESS ORAL OR WRITTEN GUARANTEES OTHER THAN THIS PRINTED LIMITED GUARANTEE. ALL IMPLICIT GUARANTEES, INCLUDING, WITHOUT LIMIT, ADAPTATION FOR A SPECIFIC USE, ARE SUBJECT TO THE DURATION OF THIS WRITTEN GUARANTEE. HI-TECH DOES NOT ASSUME ANY KIND OF COMMITMENT OR RESPONSIBILITY FOR ALL POSSIBLE DAMAGE OR EXPENSE CAUSED BY FAULTS IN THE OUTPUT OF THE PRODUCT, ITS WORKING OR THE DISPENSING OF MATERIAL THROUGH THE PRODUCT, INCLUDING, WITHOUT LIMITATION, ALL EXPENSES CAUSED BY DAMAGE TO PEOPLE OR PROPERTY. EQUALLY, HI-TECH WILL IN NO CASE ACCEPT LIABILITY FOR THE LOSS OF SPECULATIVE PROFITS OR COMMERCIAL LOSSES. ALL REPAIRS OR REPLACEMENT OF FAULTY PRODUCTS WILL CONSTITUTE THE COMPREHENSIVE FULFILMENT OF HI-TECH'S OBLIGATIONS WITH RESPECT TO THE CLIENT. HI-TECH DOES NOT IN ANY WAY GUARANTEE THE SUITABILITY OR APTITUDE OF ITS PRODUCT FOR ANY PARTICULAR PURPOSE OR APPLICATION.**

All information provided on components which have not been manufactured by HI-TECH and which is based on reports received from the original manufacturer, though considered precise and reliable, is provided without any guarantee or responsibility of any explicit or implicit kind.

All concession, sale or financial leasing of the Product by HI-TECH in no case explicitly or implicitly constitutes any authorisation, acceptance or concession for the use of any rights or patents, nor does it encourage, nurture or back their infringement.

The restrictions on the guarantee suppose no limitation on the legal rights of the consumer established in applicable national legislation, nor do they affect any rights derived from the bargain and sale agreement between the consumer and supplier.



All information provided in this manual has been included in the confidence that it is true, although it does not constitute any responsibility or implicit or explicit guarantee. HI-TECH reserves the right at any time and without prior warning to make all improvements and modifications necessary to this manual, in order to rectify any possible typographical errors, increase the information contained or insert the changes caused to the characteristics and performance of the unit.

## SAFETY AND HANDLING

The equipment described in this manual has been designed and manufactured in compliance with the following European Directives, following as application guide the harmonized standards detailed and in conformity with the relevant UK Statutory Instruments (and their amendments):



### **Directive 2006/42/EC on machinery (UK Supply of Machinery (Safety) Regulations 2008)**

UNE EN 12100:2012 (BS EN ISO 12100:2010)

### **Directive 2014/30/EU on electromagnetic compatibility (UK Electromagnetic Compatibility Regulations 2016)**

UNE EN 55011 (BS UNE EN 55011)

UNE EN 55016-2-1 (BS UNE EN 55016-2-1); UNE EN 55016-2-3 (BS UNE EN 55016-2-3);  
UNE EN 55032 (BS UNE EN 55032)

UNE EN 61000-3-2 (BS UNE EN 61000-3-2); UNE EN 61000-3-3 (BS UNE EN 61000-3-3);  
UNE EN 61000-4-2 (BS UNE EN 61000-4-2); UNE EN 61000-4-3 (BS UNE EN 61000-4-3);  
UNE EN 61000-4-4 (BS UNE EN 61000-4-4); UNE EN 61000-4-5 (BS UNE EN 61000-4-5);  
UNE EN 6100-4-6 (BS UNE EN 6100-4-6); UNE EN 61000-4-8 (BS UNE EN 61000-4-8); UNE  
EN 61000-4-11 (BS UNE EN 61000-4-11)

### **Directive 2014/68/EU on pressure equipment (UK Pressure Equipment (Safety) Regulations 2016)**

UNE EN 809:1999 +A1 (BS EN 809:1998 +A1:2009)

### **Directive 2014/35/EU on electrical safety (UK Electrical Equipment (Safety) Regulations 2016)**

UNE EN 60204-1:2019 (BS EN 60204-1:2018)

### **Directive 2003/10/EC on noise level (UK The Control of Noise at Work Regulations 2005)**

UNE EN ISO 3740 (BS EN ISO 3740:2019)

UNE EN ISO 3746 (BS EN ISO 3746:2010)

### **Directive 2011/65/EU on the restriction of the use of certain hazardous substances in electrical and electronic equipment with amendment 2015/863/EU (UK The Restriction of the Use of Certain Hazardous Substances in Electrical and Electronic Equipment Regulations 2012)**

### **Directive 2012/19/EU on waste electrical and electronic equipment (UK The Waste Electrical and Electronic Equipment Regulations 2013)**

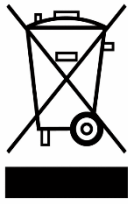

Electrical products cannot be thrown out with the rubbish. They must be taken to a dedicated collection point for an environmentally sound disposal in accordance with local regulations. You must contact your local collective or retailer for information about recycling. Before leaving WEEE at appropriate collection facilities, batteries must be removed and disposed of separately for proper recycling. The packaging materials are recyclable. Dispose of packaging materials in an environmentally sound manner and place them at the disposal of recycling sectors.

### TRANSPORT AND STORAGE

Proper precautions must be taken so that the equipment can withstand the effects of transport and storage temperatures between  $-25^{\circ}\text{C}$  and  $+55^{\circ}\text{C}$  or up to  $+70^{\circ}\text{C}$  for short periods that do not exceed 24 hours. Also, appropriate means to prevent damage from moisture, vibrations or shocks must be foreseen.

This chapter contains information on the safety, handling and use of the evolution VR series proportioning unit.



**Before installing the unit and starting it up, carefully read all the technical and safety documentation included in this Service Manual. Pay special attention to the information to know and understand the operation and the conditions of use of the unit. All of the information is aimed at enhancing User Safety and avoiding possible breakdowns derived from the incorrect use of the proportioning unit.**

**WARNING!** establishes information to alert on a situation that might cause serious injuries if the instructions are not followed.

**CAUTION!** establishes information that indicates how to avoid damage to the unit or how to avoid a situation that could cause minor injuries.

**NB:** is relevant information on a procedure being described.

Careful study of this manual will enable the operator to know the characteristics of the unit and the operating procedures. By following the instructions and recommendations contained herein, you will reduce the potential risk of accidents in the installation, use or maintenance of the unit; you will provide greater output, a better opportunity for incident-free operation for a longer time, and the possibility of detecting and resolving problems fast and simply.

Keep this Service Manual for future consultation of useful information at all times. If you lose this manual, ask for a new copy from your **HI-TECH** local distributor or directly contact **HI-TECH SPRAY EQUIPMENT, S.A.**

**WARNING!** The evolution VR series proportioning unit does not allow its use in potentially explosive atmospheres or to exceed the pressure and temperature limits described in the technical specifications of this manual.



When working with the unit, it is recommended that the operator wear suitable clothing and elements of personal protection, including, without limitation: gloves, protective goggles, safety footwear and face masks. Use breathing equipment when working with the machine in enclosed spaces or in areas with insufficient ventilation. The introduction and follow-up of safety measures must not be limited to those described in this manual. Before starting up the unit, a comprehensive analysis must be made of the risks derived from the products to be dispensed, the type of application and the working environment



***To prevent all possible bodily harm caused by incorrect handling of the raw materials and solvents used in the process, carefully read the safety information provided by your supplier.***

***Deal with the waste caused according to current regulations.***



***Disconnect the unit from the power supply before carrying out any operation inside the electrical console.***

***The electrical maintenance of the machine must only be performed by a qualified electrician.***



***To avoid damage caused by the impact of pressurized fluids, do not open any connection or perform maintenance work on components subject to pressure until the pressure has been completely eliminated.***



***Use suitable protection when operating, during maintenance or whilst remaining in the operating area of the unit. This includes, but is not limited to, the use of masks, protective goggles, gloves, shoes and safety clothing.***

***The unit includes components that reach temperatures that are liable to cause burns. The hot parts of the unit must not be handled until they have cooled.***



***To prevent serious harm by crushing or loss of limbs, do not work with the unit without the safety guards installed on all moving parts. Make sure that all of the safety protections are correctly reinstalled after all repair or maintenance work is completed.***

## CHARACTERISTICS

The **evolution VR** proportioning unit has been designed and built for the application of Polyureas, chemical systems for polyurethane foaming and some two-component epoxy systems. It features a precise automatic temperature control, pressure and mixing ratio.

### Principal Heating System

Consists of two independent heaters. Each heater has six 1500 W heating elements, that give the unit a total power of 9000 W, and the necessary control and safety components for precise operation of the system. Its singular configuration allows a temperature differential of 50° C and application temperatures of up to 90° C under normal conditions of ambient temperature.

### Hose Heating System

Designed with two 4000 W transformers each, which enable effective, independent heating up to a total hose length of 93 meters (305 ft). The system includes an innovative hose heating concept in which the copper heating element is spread evenly around the circumference of the hose, providing a uniform heating watt density and precise control of the product application temperature.



### Double Acting Piston Proportioning Pumps

Driven by two double acting piston hydraulic cylinders to deliver constant output and guarantee pressure stability for both displacement directions of the pumps. Several pump sizes can be incorporated, helping to obtain the required minimum and maximum flow in the standard setup of the unit.

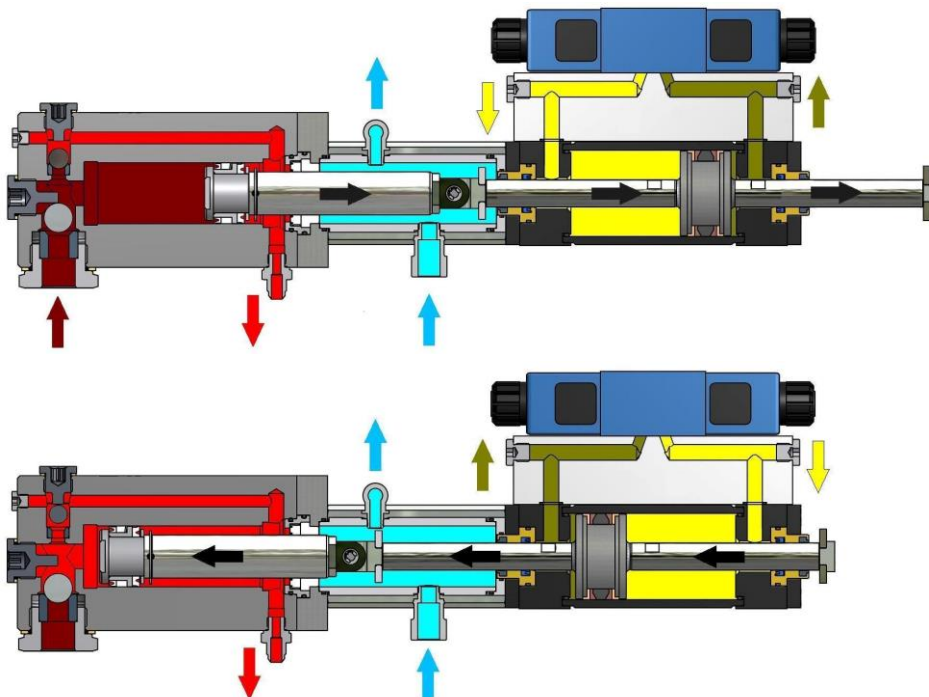



### **Recirculation System**

The recirculation system allows heating the products automatically, therefore reducing the time of preparation prior to start spraying. The system features a manual valve to close the recirculation system at one's discretion. When in recirculation mode, products pushed by the proportioning pumps flow through the heaters and go back to the feeding tanks.

### **Central Processing Unit (CPU)**

The CPU's software processes and controls all program instructions depending on the application parameters entered on the screens. Any alteration that may occur affecting the set parameters will be corrected while the unit continues working. When the problem cannot be resolved within the established tolerance parameters, the CPU will stop the unit and will display the type of failure occurred.



## TECHNICAL SPECIFICATIONS

### Electrical

Main voltage (EU): \_\_\_\_\_ 400 V  
Frequency: \_\_\_\_\_ 50/60 Hz  
Electrical consumption (EU): \_\_\_\_\_ 54-62 A @ 3PE~400 V  
Heaters power: \_\_\_\_\_ (2 x 9 kW) 18 kW  
Hose Transformers Power: \_\_\_\_\_ (2 x 4 kW) 8 kW  
Electrical Motor Power: \_\_\_\_\_ (2 x 3 kW), (2 x 4 kW) 6-8 kW  
Total Active Power: \_\_\_\_\_ 32-34 kW



**There are three terminals for the main supply cable connection (wire not supplied) in the control box. The electrical connection of the unit must be carried out by a qualified electrician.**

### Mechanical

Maximum working pressure: \_\_\_\_\_ 275 kgf/cm<sup>2</sup> (27 MPa)  
Maximum production ratio 1:1 \_\_\_\_\_ 15 kg/min  
Minimum production: \_\_\_\_\_ 1 kg/min  
Maximum hose length: \_\_\_\_\_ 93 m  
Recommended compressor: \_\_\_\_\_ Three-phase 3 HP

### Acoustic

A-weighted sound pressure level: \_\_\_\_\_ 78,4 dB (A)  
A-weighted sound power level: \_\_\_\_\_ 93,5 dB (A)

**Values obtained according to UNE-EN ISO 3746:1995 standard.**

Approximate weight (hydraulic tank empty): \_\_\_\_\_ 450 kg  
Approximate weight (hydraulic tank full): \_\_\_\_\_ 545 kg  
Dimensions: \_\_\_\_\_ H: 125 cm / W: 111 cm / L: 120 cm



3PE~400V 50/60Hz





## GENERAL DESCRIPTION MAIN COMPONENTS

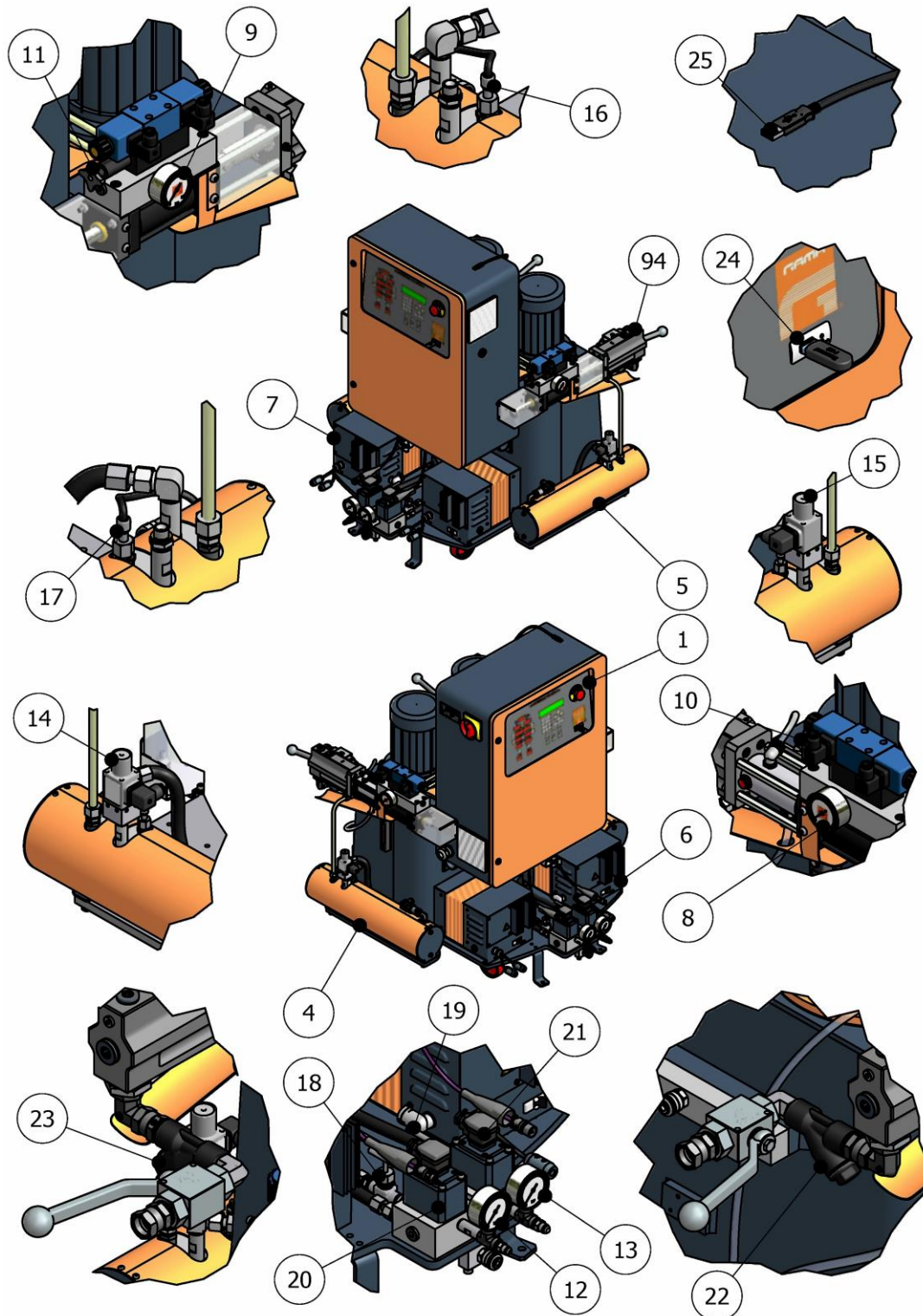



**1. Control Panel**

Controls and regulates the operation of the unit.

**2. Isocyanate Proportioning Pump**

Provides the system with Isocyanate.

**3. Polyol Proportioning Pump**

Provides the system with Polyol.

**4. Isocyanate Heater**

Heats the Isocyanate to the pre-set temperature.

**5. Polyol Heater**

Heats the Polyol to the pre-set temperature.

**6. Polyol Hose Heating Transformer**

Supplies the required voltage for the heating of the Polyol hoses.

**7. Isocyanate Hose Heating Transformer**

Supplies the required voltage for the heating of the Isocyanate hoses.

**8. Isocyanate Hydraulic Pressure Gauge**

Indicates the pressure in the Isocyanate hydraulic circuit.

**9. Polyol Hydraulic Pressure Gauge**

Indicates the pressure in the Polyol hydraulic system.

**10. Isocyanate Hydraulic Circuit Safety Valve**

Diverts pressure to the hydraulic tank in the event of excessive pressure in the Isocyanate system.

**11. Polyol Hydraulic Circuit Safety Valve**

Diverts pressure to the hydraulic tank in the event of excessive pressure in the Polyol system.

**12. Isocyanate Pressure Gauge**

Indicates the pressure of the Isocyanate circuit.

**13. Polyol Pressure Gauge**

Indicates the pressure of the Polyol system.

**14. Isocyanate Safety Pressure Switch**

Stops the Isocyanate pump motor in the event of excessive pressure in the circuit.

**15. Polyol Safety Pressure Switch**

Stops the Polyol pump motor in the event of excessive pressure in the circuit.

**16. Isocyanate Temperature Probe**

Provides information on the temperature of the Isocyanate..

**17. Polyol Temperature Probe**

Provides information on the temperature of the Polyol.

**18. Isocyanate Needle Valve**

Adjusts the recirculation pressure of the Isocyanate.

**19. Polyol Needle Valve**

Adjusts the recirculation pressure of the Polyol.

**20. Isocyanate Flow Meter**

Provides information about the volumetric flow supplied by the Isocyanate pump.

**21. Polyol Flow Meter**

Provides information about the volumetric flow supplied by the Polyol pump.

**22. Isocyanate Inlet Filters**

Avoid the penetration of solid particles inside the Isocyanate pump of the unit. The standard filter size is 30 Mesh. (Optionally available 20/60/80 Mesh).

**23. Polyol Inlet Filters**

Avoid the penetration of solid particles inside the Polyol pump of the unit. The standard filter size is 30 Mesh. (Optionally available 20/60/80 Mesh).

**24. USB port for data to be stored in an external storage unit**

This allows a massive storage unit to be connected to collect details of the unit operation.

**25. Airborne USB port for connecting on-line to an external PC**

This allows an external PC to be connected to the machine for the on-line processing of the data generated by the metering unit.

**26. USB output port directing selector**

This allows the predetermined USB port to be directed for data output (PC-VDRIVE).

**27. DIP3 Selector**

This allows the connection of an external PC to the machine to be selected for the on-line processing of the data generated by the metering unit.

**NOTE:** In “VDRIVE” position and with DIP3 “OFF”: this enables data to be caught in the massive storage device located on the front of the machine.

In “PC” position and with DIP3 “ON”; this allows the on-line processing of the data in a PC connected by means of the airborne USB port.

**28. Pressure Unit DIP Selector**

This enables the pressure and temperature units to be selected, which are shown on the displays of the control panel. Turn the selector to EU for the pressure to be expressed in **bar** and the temperature units to be expressed in degrees **Celsius**. Turn the selector to USA for the pressure to be expressed in **psi** and the temperature units to be expressed in degrees **Fahrenheit**.

**NOTE:** The unit must be turned off to be able to work on the DIP selector.

**29. Pressure Transducers DIP Selector**

This enables the kind of transducers installed in the unit to be selected (4-20 mA) / (0-10 V); the selection will be done in the factory and shall not be modified without previous authorisation from the **HI-TECH** technical service.

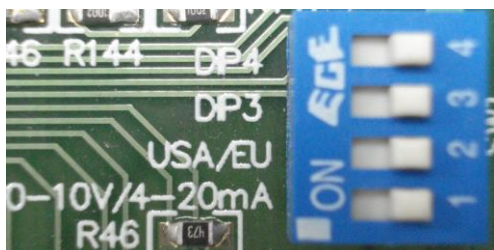

**NOTE:** The unit must be turned off to be able to work on the DIP selector.

## CONTROL PANEL

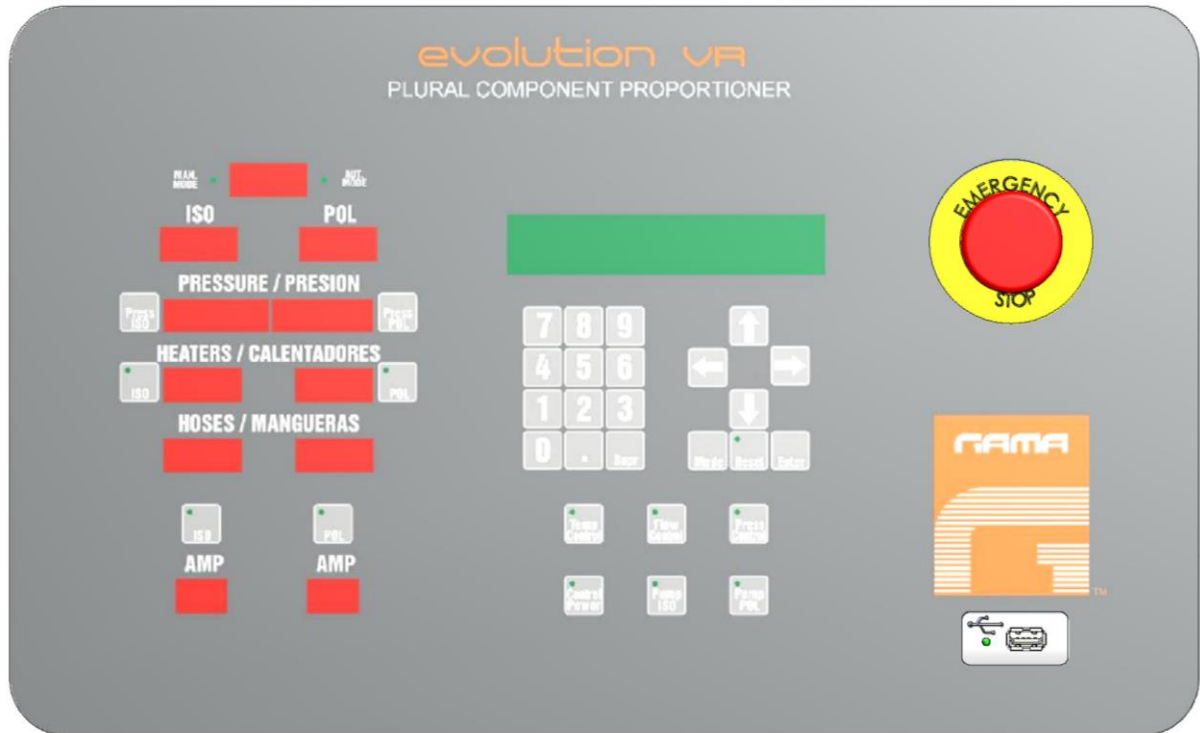

The Control Panel allows the optimum working conditions to be set and visualized, depending on the characteristics and requirements of the products to be dispensed.

Using the **MODE** key, the different parameters setting and control screens may be entered.

Use **LEFT / RIGHT** to enter the different parameters.

Those parameters flashing in the screens can be modified; fixed parameters are shown for information. By pressing the **UP / DOWN** keys, you will be able to increase or decrease the value of each parameter. Requested parameters can equally be entered from the numeric keypad.

Once the required value is set, press the **ENTER** key to confirm set up.

### Main Power Switch

Turns the electric supply to the control panel on and off. It must be turned **ON** for any operation to be performed with the unit. When turned **ON**, the LCD screen in the control panel will light.

### Ventilation System

The Control Panel is equipped with a fan and an extractor in order to avoid overheating of its electrical components. The filters in the fan and the extractor must be cleaned once a month.

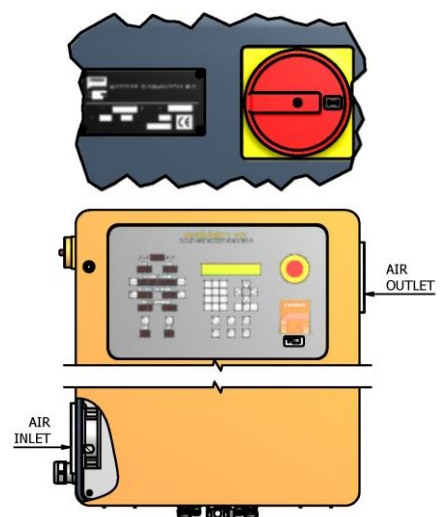

## Service Manual

### Audible Alarm

Should the unit present problems provoked by alterations in the correct functioning, an audible alarm warning will sound and will be shown in the LCD screen. Press **RESET** to stop the acoustic sound.

The system does not allow resetting an alarm if the problem that provoked it has not been resolved.

### Hoses

The displays show the temperature of the Isocyanate hose (ISO) and the temperature of the Polyol hose (POL). The hose heating control is automatic in this unit.

To enter or modify the value of the temperature, press the **MODE** key as many times as necessary until you reach the “**HOSES TEMP**” screen (see page 19). Then press **UP/DOWN** or enter the required value from the numeric keypad. Press the **MODE** key to enter the selected value into memory. Repeat the process to select the Amps from the “**HOSES AMPS**” screen (see page 19).

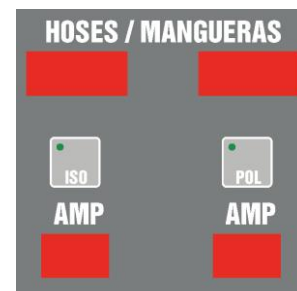

The push-buttons turn on or off the hose heating system of each product. Each push-button has a led that lights when the heater is on; if the led flashes, it indicates that the system is not heating; if the led lights steady, it indicates that the system is heating.

If the TCS stops working, the temperature display will show the symbol (---) and the heating will be automatically turned off.

Using the DIP selector labeled USA and EU, the units of pressure and temperature can be set. Set the DIP selector to EU for the pressure to be displayed in bar and the temperature in degrees **Celsius**; set the DIP selector to USA for the pressure to be displayed in psi and the temperature in degrees **Fahrenheit**.

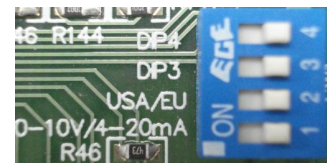

**NOTE:** Please bear in mind that whilst manipulating the DIP selector the unit must be switched off.

### Heaters

The display shows the temperature in the Isocyanate heater (ISO) and the temperature in the Polyol heater (POL). Temperature control is automatic in this unit.



To enter or modify the value of the temperature, press the **MODE** key as many times as necessary until you reach the “**HEATERS TEMP**” screen (see page 19). Then press **UP/DOWN** or enter the required value from the numeric keypad. Press the **MODE** key to enter the selected value into memory.

The push-buttons turn on or off the heater of each product. Each push-button has a led that lights when the heater is on; if the led flashes, it indicates that the system is not heating; if the led lights steady, it indicates that the system is heating.

If the TCS stops working, the temperature display will show the symbol (---) and the heating will be automatically turned off.

Using the DIP selector labeled USA and EU, the units of pressure and temperature can be set. Set the DIP selector to EU for the pressure to be displayed in **bar** and the temperature in degrees **Celsius**; set the DIP selector to USA for the pressure to be displayed in **psi** and the temperature in degrees **Fahrenheit**.

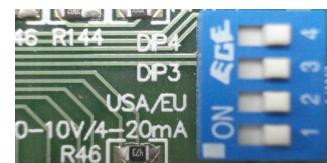

**NOTE:** Please bear in mind that whilst manipulating the DIP selector the unit must be switched off.

**Pressure**

Indicators display the Isocyanate pressure (ISO) and the Polyol (POL).

In order to pressurize each component's circuit, keep **ISO** or **POL** pressed, until the requested working pressure is achieved.



The maximum pressurization value must be established as the maximum value in the "PRESSURE ISO/POL" screens (see page 18).

This operation must be done with the motors stopped and the **POWER CONTROL** key activated.

Using the DIP selector labeled USA and EU, the units of pressure and temperature can be set. Set the DIP selector to EU for the pressure to be displayed in **bar** and the temperature in degrees **Celsius**; set the DIP selector to USA for the pressure to be displayed in **psi** and the temperature in degrees **Fahrenheit**.

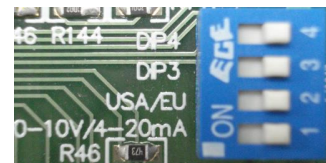

**NOTE:** Please bear in mind that whilst manipulating the DIP selector the unit must be switched off.

**ISO / POL Output Displays**

If your unit does not have flow meters, **ISO / POL** displays will show the frequency (**Hertz**) of the motor that activates the hydraulic pump of each circuit. If your unit has flow meters, **ISO / POL** displays will show the **grams/second** dispensed by each component's pump.



**Total Output Display**

When the unit works with flow meters, the display shows the total real output (**grams / second**) of both components.



**Automatic / Manual Mode**

The lit led indicates the working mode established in the LCD screen (see page 17).





**Power Control Key**

Turns on and off the control voltage to the electrical circuit of the heaters, the hoses heating system, and the frequency converters. When the key is on, the LCD screen and the led placed at the left top part light on. It may turn off voluntarily if the key is pressed again or automatically if an alarm is caused due to excessive temperature in the heaters or due to excessive current in the hose heating system.

**ISO Pump / POL Pump Key**

Turns on and off the motors which activate the hydraulic pumps. When the key is on, the left top led is lit. It may turn off voluntarily if the key is pressed again or automatically if an electric intensity overcharge in the motors or excessive pressure in the ISO / POL circuits is produced.

**Temp Control Key**

Turns on and off the preset **ISO / POL** temperature **tolerance** control in the hoses.

The system is activated once the preset temperature has been reached, and 10 seconds after the magnetic switch in the spray gun has turned on the solenoid valves which make the proportioning pumps start working. It allows temperatures to stay out of ratio for the mentioned 10 seconds plus the time set at the **“TOLERANCE DELAY”** (see page 24). The alarm of the unit will sound after 10 seconds from the start of the pumping plus the set time for the delay, if the temperature of the components is not within the set tolerance.

**Flow Control Key**

Turns on and off the preset **ISO / POL** mixing ratio **tolerance** control.

The system is activated 10 seconds after the magnetic switch in the spray gun has turned on the solenoid valves which make the proportioning pumps start working. It allows the mixing ratio to stay out of ratio for the mentioned 10 seconds plus the time set at the **“TOLERANCE DELAY”** (see page 24). The alarm of the unit will sound after 10 seconds from the start of the pumping plus the set time for the delay, if the mixing ratio is not within the set tolerance.

**Press Control Key**

Turns on and off the preset **ISO / POL** pressure **tolerance** control.

The system is activated 10 seconds after the magnetic switch in the spray gun has turned on the solenoid valves which make the proportioning pumps start working. It allows the pressures to stay out of ratio for the mentioned 10 seconds plus the time set at the **“TOLERANCE DELAY”** (see page 24). The alarm of the unit will sound after 10 seconds from the start of the pumping plus the set time for the delay, if the pressures are not within the set tolerance.

**Mode Key**

Allows access to the different screens for the setup of the working parameters.

**Reset Key**

Turns the audible alarm off and restores the system in its initial conditions.

The system does not allow to reset an alarm if the problem that provoked it has not been resolved before.

*The led placed in the left top part of the key lights on when an alarm turns on, and flashes rapidly when the magnetic switch of the spray gun is activated.*

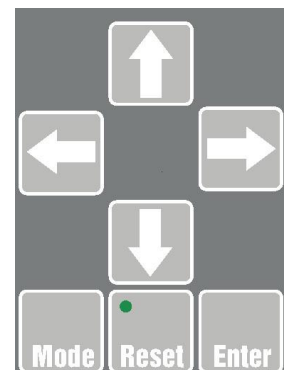



**Enter Key**

Allows confirming and memorizing of the new parameters which have been entered or modified in the different screens.

**Up / Down Keys**

Allow the value of each of the parameters and the selection of the preset working options to be increased or decreased.

**Right / Left Keys**

Allow movement of the cursor to access the different parameters and screens.

**Numeric Keypad**

Allows entering or altering the values of each parameter. In case of mistake, use the **SUPR** key to cancel the last digit that you have introduced.







## CONTROL SCREENS

**NOTE:** Those parameters flashing in the screens can be modified; fixed parameters are shown for information.

### Language Selection Screen

*	*	*	*	*	*	L	A	N	G	U	A	G	E	*	*	*	*	*	*
						E	N	G	L	I	S	H							

This screen appears when the unit is switched on for the first time. It will only be visible this first time.

Allows setting of the text in five different languages: Spanish, Italian, English, German, and French.

Use **UP/DOWN** to go from one language to another. Press **ENTER** to confirm and finalize the setup of the languages.

### Unit Model Screen

		E	V	O	L	U	T	I	O	N		V	R						
G	A	M	A		S	P	R	A	Y		E	Q	U	I	P	M	E	N	T

Shows the model of proportioning unit.

### Output Selection Screen

O	U	T	P	U	T							g	/	s	:	0	0	0	0
M	I	N															M	A	X

Allows establishing the total gr/sec requested for both chemical components. The CPU will calculate the gr/sec to be dispensed depending on the mixing ratio and the densities set for each component.

The bottom menu shows the maximum and minimum gr/sec that can be selected depending on the characteristics of the hydraulic pumps mounted on the unit.

Use **UP/DOWN** to increase or decrease the value of the gr/sec, or enter the new value from the numeric keypad.

Once the requested value has been established, press **ENTER** to confirm and finalize the setup.

**NOTE:** This screen will not appear if you have selected “Manual” working mode with flow meters activated.



Hertz Selection Screen

								<b>H</b>	<b>e</b>	<b>r</b>	<b>t</b>	<b>z</b>								
<b>I</b>	<b>S</b>	<b>O</b>		<b>0</b>	<b>0</b>	<b>0</b>	<b>0</b>						<b>0</b>	<b>0</b>	<b>0</b>	<b>0</b>		<b>P</b>	<b>O</b>	<b>L</b>

Selection of Manual mode with flow meters activated (see page 17) allows establishing the feeding frequency (Hertz) of the motors that turn the hydraulic pumps on.

The range of regulation is 20 to 100 Hertz, with rises of 0.1 Hertz.

Should the Automatic mode with flow meters activated (see page 17) be selected, the screen will show the equivalent Hertz to the gr/sec dispensed by the unit. It will not be possible to make any adjustment to the flow meters.

One can visually appreciate the automatic correction that the CPU of the unit makes using the information received constantly from the flow meters.

If the unit does not have flow meters, the screen will show the equivalent Hertz to the gr/sec established in the Output Screen. The adjustment can be carried out with a +/- 2% precision.

The flashing value can be modified using **UP/DOWN** or entering the new value from the numeric keypad. Use **RIGHT/LEFT** to go from one product to the other (ISO/POL).

Once the requested value has been established, press **ENTER** to confirm and finalize the setup.

Drums Material Screen

<b>D</b>	<b>R</b>	<b>U</b>	<b>M</b>	<b>S</b>		<b>M</b>	<b>A</b>	<b>T</b>	<b>E</b>	<b>R</b>	<b>I</b>	<b>A</b>	<b>L</b>					<b>K</b>	<b>g</b>	
<b>I</b>	<b>S</b>	<b>O</b>		<b>0</b>	<b>0</b>	<b>0</b>	<b>0</b>						<b>0</b>	<b>0</b>	<b>0</b>	<b>0</b>		<b>P</b>	<b>O</b>	<b>L</b>

Shows the kilograms of product inside the feeding drums.

Once the initial quantity inside the drums has been established, the CPU will deduce the kilograms as they keep consuming. When any of both components reaches "0" value, a audible alarm will turn on, the motors of the unit will stop and the screen will show **EMPTY DRUM**.

Press **RESET** to turn the alarm off.

In case you wish to change the value of kilograms established initially, select the new value from the numeric keypad. Press **RESET** again to maintain the same initial value,

The decreasing counter will be activated when a positive value between 1 and 9,999 kilograms is entered, with rises of 1 kg.

The flashing value of kilograms can be modified using **UP/DOWN** or entering the new value from the numeric keypad. Use **RIGHT/LEFT** to go from one product to the other (ISO/POL).

Once the requested value has been established, press **ENTER** to confirm and finalize the setup.

**NOTE:** This screen will only appear if you have selected the "ON" flow meters option.



**Working Mode Selection Screen**

				W	O	R	K	I	N	G			M	O	D	E			
				A	U	T	O	M	A	T	I	C							

Allows selecting the operating mode of the unit: **Automatic** or **Manual**.

The **Automatic** Mode with **flow meters activated (CLOSED CIRCUIT)** allows the CPU to receive constant information about the volumetric flow dispensed by each pump. It also allows to correct automatically those Derivations produced in relation to the preset gr/sec to dispense and the mixing ratio.

The **Manual** Mode with **flow meters activated (OPEN CIRCUIT)** allow setting the feeding frequency (Hertz) of the motors that turn the hydraulic pumps on. This working mode is adequate in the following scenarios: when calibration of the components is needed, when working tests of the unit before changing to automatic mode are needed, when maintenance and cleaning (e.g. when one product circuit needs cleaning) are needed, or whenever it becomes convenient to compare the parameters visualized in the display in closed circuit.

Use **UP/DOWN** to select either option. Press **ENTER** to confirm and finalize the setup.

**Density Selection Screen**

D	E	N	S	I	T	Y												g	/	c	m <sup>3</sup>		
I	S	O		0	.	0	0	0				0	.	0	0	0					P	O	L

Allows establishing the density value of each chemical component.

The measuring unit for the density must be g/cm<sup>3</sup>

**IMPORTANT:** *Whenever the mixing ratio comes in volume, the density value of ISO and POL must be 1. However, if the mixing ratio comes in weight, densities indicated by the chemical product supplier must be entered.*

The flashing value can be modified using **UP/DOWN** or entering the new value from the numeric keypad. Use **RIGHT/LEFT** to go from one product to the other (ISO/POL).

Once the requested value has been established, press **ENTER** to confirm and finalize the setup.

**NOTE:** *Both motors of the unit must be stopped if you wish to modify or enter new values. The magnetic switch of the spray gun must be in OFF position.*

**Mixing Ratio Selection Screen**

				M	I	X							R	A	T	I	O						
I	S	O		0	.	0	0	0				0	.	0	0	0					P	O	L

Allows establishing the mixing ratio between both chemical components, both in weight or volume.

The flashing value can be modified using **UP/DOWN** or entering the new value from the numeric keypad. Use **RIGHT/LEFT** to go from one product to the other (ISO/POL).

Once the requested value has been established, press **ENTER** to confirm and finalize the setup.



**NOTE:** Both motors of the unit must be stopped if you wish to modify or enter new values. The magnetic switch of the spray gun must be in OFF position.

ISO Pressure Selection Screen

I	S	O		P	R	E	S	S	U	R	E						b	a	r
M	I	N		0	0	0	0					0	0	0	0		M	A	X

Allows establishing the minimum and maximum spraying pressure in the Isocyanate circuit.

Place the DIP in USA position if you wish the pressure unit to be **psi**; place the DIP in EU position if you wish the pressure unit to be **bar**.

If the **PRESS CONTROL** key is activated, the CPU of the unit will ensure that the pressure in the Isocyanate circuit is within the established limits. Should the pressure of the circuit be over the maximum value or below the minimum, the audible alarm of the unit will turn on and the motors will stop. The screen will show "**PRESSURE OUT OF TOLERANCE**".

The pressure tolerance control system is activated 10 seconds after the magnetic switch in the spray gun has turned on the solenoid valves which make the proportioning pumps start working. It allows pressure to stay out of ratio for the mentioned 10 seconds plus the time set at the "**TOLERANCE DELAY**" (see page 24). The alarm of the unit will sound after 10 seconds from the start of the pumping plus the set time for the delay, if the mixing ratio is not within the set tolerance.

The flashing value can be modified using **UP/DOWN** or entering the new value from the numeric keypad. Use **RIGHT/LEFT** to go from one option to the other (MIN/MAX).

Once the requested value has been established, press **ENTER** to confirm and finalize the setup.

POL Pressure Selection Screen

P	O	L		P	R	E	S	S	U	R	E						b	a	r
M	I	N		0	0	0	0					0	0	0	0		M	A	X

Allows establishing the minimum and maximum spraying pressure in the Polyol circuit.

Place the DIP in USA position if you wish the pressure unit to be **psi**; place the DIP in EU position if you wish the pressure unit to be **bar**.

If the **PRESS CONTROL** key is activated, the CPU of the unit will ensure that the pressure in the Polyol circuit is within the established limits. Should the pressure of the circuit be over the maximum value or below the minimum, the audible alarm of the unit will turn on and the motors will stop. The screen will show "**PRESSURE OUT OF TOLERANCE**".

The pressure tolerance control system is activated 10 seconds after the magnetic switch in the spray gun has turned on the solenoid valves which make the proportioning pumps start working. It allows pressure to stay out of ratio for the mentioned 10 seconds plus the time set at the "**TOLERANCE DELAY**" (see page 24). The alarm of the unit will sound after 10 seconds from the start of the pumping plus the set time for the delay, if the mixing ratio is not within the set tolerance.

The flashing value can be modified using **UP/DOWN** or entering the new value from the numeric keypad. Use **RIGHT/LEFT** to go from one option to the other (MIN/MAX).

Once the requested value has been established, press **ENTER** to confirm and finalize the setup.



**Heaters Temperature Selection Screen**

H	E	A	T	E	R														°	C			
I	S	O		0	0	0															P	O	L

Allows establishing the set temperature in the heaters of the components.  
 Set the DIP selector to EU for the temperature to be displayed in degrees **Celsius**; set the DIP selector to USA for the temperature to be displayed in degrees **Fahrenheit**.  
 The range of temperatures goes from 0 °C to 90 °C (32 °F to 194 °F), with rises of 1°C (34 °F).  
 The flashing value can be modified using **UP/DOWN** or entering the new value from the numeric keypad. Use **RIGHT/LEFT** to go from one product to the other (ISO/POL).  
 Once the requested value has been established, press **ENTER** to confirm and finalize the setup.

**Hoses Temperature Selection Screen**

H	O	S	E																	°	C				
I	S	O		0	0	0																	P	O	L

Allows establishing the set temperature in the hoses of the components.  
 Set the DIP selector to EU for the temperature to be displayed in degrees **Celsius**; set the DIP selector to USA for the temperature to be displayed in degrees **Fahrenheit**.  
 The range of temperatures goes from 0 °C to 80 °C (32 °F to 176 °F), with rises of 1°C (34 °F).  
 The flashing value can be modified using **UP/DOWN** or entering the new value from the numeric keypad. Use **RIGHT/LEFT** to go from one product to the other (ISO/POL).  
 Once the requested value has been established, press **ENTER** to confirm and finalize the setup.  
 Hose temperature settings that are higher than the temperature settings of the heaters cannot be programmed.  
 If only one temperature control system is working (ISO or POL), the limiting temperature value will be the highest set in the heaters.  
 If both temperature control systems are working (ISO and POL), the limiting value will be related to each of their corresponding heaters.  
 Temperature settings are restricted to 80°C maximum for hoses and 90°C maximum for heaters.

To enter data, the order will be as follows:

- The temperatures in ISO and POL heaters are set.
- The temperatures in ISO and POL hoses are set.
- Finally, the settings of the rest of the data can be entered in the date range and cycle pre-selector.



### Hoses Electrical Intensity Selection Screen

H	O	S	E	S													A	m	p	s
I	S	O		0	0								0	0			P	O	L	

Allows establishing the electrical current intensity to be applied to the resistance of each hose.

The range of regulation goes from 10 to 50 Amps, with rises of 1 Amp.

Since the unit always works with automatic temperature control, the value of the current intensity must be set usually between 45 and 50 Amps.

The flashing value can be modified using **UP/DOWN** or entering the new value from the numeric keypad. Use **RIGHT/LEFT** to go from one product to the other (ISO/POL).

Once the requested value has been established, press **ENTER** to confirm and finalize the setup.

### Shooting Time Screen

S	H	O	O	T	I	N	G		T	I	M	E								s
0	0	.	0					O	F	F				0	0	.	0			

Allows establishing the time of spraying or injection.

To activate the time counter system, select option “**ON**” in the central menu of the screen by pressing **UP/DOWN** keys.

If the spraying or injection are done manually, the shooting time will start counting when the spray gun trigger is pushed, and the inductive detector is activated. The gun will close once the time established in the screen is finished.

The requested time must be established in the right-hand menu of the screen. The CPU counter will deduct the seconds gone from the beginning of the shot until the total time established has finished. Once 0 value is reached, the gun will close automatically and the unit will beep.

The time unit is seconds and the selection range is between 0 and 999.9 seconds, with rises of 0.1 seconds.

Should an alarm turn on during the shooting time, the counter will stop and show the seconds remaining until the total established shooting time.

Resolve the problem caused by the alarm and activate the trigger again to consume the remaining time, or press **RESET**, with no need to exit the current screen, to re-establish the total time from the beginning.

The time established initially is shown in the left-hand menu of the screen.

The time counter will only be activated again after the trigger is released and the detector has lost its signal.

Use **UP/DOWN** to modify the established time, or else enter the new value from the numeric keypad. Use **RIGHT/LEFT** to go from one menu to another.

**NOTE:** This working mode is optional, the basic proportioning unit will need to incorporate additional components and an automatic gun to operate with the timer.



Recirculation Parameters Selection Screen

				<b>R</b>	<b>E</b>	<b>C</b>	<b>I</b>	<b>R</b>	<b>C</b>	<b>U</b>	<b>L</b>	<b>A</b>	<b>T</b>	<b>I</b>	<b>O</b>	<b>N</b>				
				<b>°</b>	<b>C</b>	<b>:</b>	<b>0</b>	<b>0</b>	<b>0</b>	<b>O</b>	<b>N</b>	<b>:</b>	<b>0</b>	<b>0</b>	<b>O</b>	<b>F</b>	<b>F</b>	<b>:</b>	<b>0</b>	<b>0</b>

Set temperature for both heaters during the time that recirculation will remain active is set in the first menu (left-hand side).

The range of temperatures goes from 0 °C to 90 °C (32 °F to 194 °F), with rises of 1°C (34 °F).

Heaters are automatically activated when the set temperature is over the room temperature.

Set the DIP selector to **EU** for the temperature to be displayed in degrees **Celsius**; set the DIP selector to **USA** for the temperature to be displayed in degrees **Fahrenheit**.

The time that recirculation will remain active is set in the central menu.

The time unit is minutes and the selection range is between 1 and 99 minutes, with rises of 1 minute.

**NOTE:** *Should any alarm turn on at some stage, recirculation will turn off automatically.*

Recirculation pause time is set in the third menu (right-hand side). During this time, the motors which turn the hydraulic pumps on will remain stopped until automatic recirculation is turned on again.

The time unit is minutes and the selection range is between 1 and 99 minutes, with rises of 1 minute.

The flashing value can be modified using **UP/DOWN** or entering the new value from the numeric keypad. Use **RIGHT/LEFT** to go from one menu to another.

Once the requested value has been established, press **ENTER** to confirm and finalize the setup.

**NOTE:** *Recirculation will only turn on if both the first menu and the central menu show a positive value between 1 and 99.*

POL Recirculation Selection Screen

<b>I</b>	<b>S</b>	<b>O</b>			<b>R</b>	<b>E</b>	<b>C</b>	<b>I</b>	<b>R</b>	<b>C</b>	<b>U</b>	<b>L</b>	<b>A</b>	<b>T</b>	.		<b>P</b>	<b>O</b>	<b>L</b>
<b>O</b>	<b>F</b>	<b>F</b>							<b>O</b>	<b>F</b>	<b>F</b>						<b>O</b>	<b>F</b>	<b>F</b>

Allows activating the automatic recirculation system of each product.

Follow the steps below to activated the recirculation system:

- Open the valve of the product to re-circulate, only in those units with manual recirculation. This step is not necessary in those units with automatic recirculation valve.
- Turn the manual handle of the needle valve of the product to be re-circulated anti-clockwise to the end.
- Turn the main switch to the **“ON”** position.
- Press the **POWER CONTROL** key. The top led in the key will light on.
- Establish the temperature of the products (**see previous screen**).
- Establish the time that it will remain active (**see previous screen**).
- Establish the time that will remain on stand by (**see previous screen**).
- Select the **ON** option in the product to be re-circulated (ISO/POL).



- Select the **ON** option to activate the recirculation. The unit will beep when the recirculation is activated.
- To pressurize the recirculation circuit (approx. 50 bar), turn the manual handle of the needle valve of the product to be re-circulated clockwise to the end.

The turning frequency of the two motors that turn the hydraulic pumps on during the recirculation time is 20 Hz (580 r.p.m.)

**NOTE:** Should any alarm turn on at some stage, recirculation will turn off automatically.

**Hoses Temperature Control Selection Screen**

H	O	S	E	S		T	E	M	P		C	O	N	T	R	O	L	°	C	
I	S	O		0	0									0	0			P	O	L

Allows establishing the maximum Derivation (tolerance) of the temperature in the hoses,, with respect to the nominal values established in the Hose Temperature Selection Screen (ISO/POL) Tolerance is symmetrical: **nominal value +/- the established value**. Any Derivation, by excess or by defect, produced out of the established limits, will make the audible alarm be activated and the motors of the unit be stopped. The screen will show the “**hose temperature out of tolerance ISO or POL**” warning.

The flashing value can be modified using **UP/DOWN** or entering the new value from the numeric keypad. Use **RIGHT/LEFT** to go from one product to the other (ISO/POL).

Once the requested value has been established, press **ENTER** to confirm and finalize the setup.

Set the DIP selector to EU for the temperature to be displayed in degrees **Celsius**; set the DIP selector to USA for the temperature to be displayed in degrees **Fahrenheit**.

**NOTE:** Press **TEMP CONTROL** in the control panel to activate the temperature control,, then establish a positive value between 1 and 80 °C. The range of temperatures goes from 0 °C to 80 °C (32 °F to 176 °F), with rises of 1°C (34 °F) in the product that we wish to control.

**Flow Control Selection Screen**

F	L	O	W			C	O	N	T	R	O	L						g	/	s
I	S	O		0	0									0	0			P	O	L

Allows establishing the maximum Derivation (tolerance) of gr/sec, with respect to the nominal values established in the output displays ISO/POL.

Tolerance is symmetrical: **nominal value +/- the established value**. Any Derivation, by excess or by defect, produced out of the established limits, will make the audible alarm be activated and the motors of the unit be stopped. The screen will show the “**hose temperature out of tolerance ISO or POL**” warning.

The flashing value can be modified using **UP/DOWN** or entering the new value from the numeric keypad. Use **RIGHT/LEFT** to go from one product to the other (ISO/POL).

Once the requested value has been established, press **ENTER** to confirm and finalize the setup.





**NOTE:** Press **FLOW CONTROL** in the control panel to activate the flow control, then establish a positive value between 0 and 99 gr/sec, with rises of 1 gr/sec in the product that we wish to control.

**Password Introduction Screen**

C	O	N	S	T	A	N	T	S			M	E	N	U				
P	A	S	S	W	O	R	D	:		0	0	0						

The CPU of the unit has a password function to prevent incorrect manipulation of the factory pre-set constants by unauthorized operators.

The numeric interval of the password is between 000 and 999. The factory pre-set password must be known to access the password screens.

Enter the **PASSWORD** through the numeric keypad and press **ENTER** and **MODE** keys.

**NOTE:** All the constants in the screens that will be shown next are factory pre-set. They should not be modified without permission from **HI-TECH SPRAY EQUIPMENT, S.A. qualified technical personnel.**

**Revision Level Visualization Screen**

						V	E	R	S	I	O	N						
F	P	:	1										B	A	S	E	:	1

Allows visualizing the revision status of the control panel and the CPU.

**Date Configuration Screen**

		D	A	T	E			A	D	J	U	S	T	M	E	N	T		
Y	E	A	R	0	0	0	0	M	O	N	T	H	0	0	D	A	Y	0	0

Allows establishing the date (YEAR / MONTH / DAY).

The flashing value can be modified using **UP/DOWN** or entering the new value from the numeric keypad. Use **RIGHT/LEFT** to go from one datum to the other (YEAR / MONTH / DAY).

Once the requested value has been established, press **ENTER** to confirm and finalize the setup.

**NOTE:** Ensure that the date is formed correctly when a **DATA LOGGER** is connected.

**Clock Configuration Screen**

		C	L	O	C	K			A	D	J	U	S	T	M	E	N	T		
H	O	U	R	:	0	0					M	I	N	U	T	E	:	0	0	

Allows establishing the hour and minutes.

The flashing value can be modified using **UP/DOWN** or entering the new value from the numeric keypad. Use **RIGHT/LEFT** to go from one datum to the other (HOUR / MINUTE).



Once the requested value has been established, press **ENTER** to confirm and finalize the setup.

**NOTE:** Ensure that the date is formed correctly when a **DATA LOGGER** is connected.

Winter / summer automatic time change is not formed.

**Delay Time Selection Screen**

	T	O	L	E	R	A	N	C	E			D	E	L	A	Y			
<b>M</b>	<b>A</b>	<b>X</b>	:	<b>3</b>	<b>0</b>				<b>0</b>	<b>0</b>					<b>M</b>	<b>I</b>	<b>N</b>	:	<b>0</b>

Allows establishing the time delay before the audible alarm of the unit is activated.

The time delay counter will be activated whenever some flow, pressure or temperature control is activated and any variation out of the established tolerances is produced.

The time unit is seconds and the selection range is between 0 and 30 seconds, with rises of 1 second.

Use **UP/DOWN** to increase or decrease the seconds or enter the new value from the numeric keypad.

Once the requested value has been established, press **ENTER** to confirm and finalize the setup.

**Pumps Product Selection Screen**

			P	R	O	D	U	C	T			P	U	M	P	S			
<b>I</b>	<b>S</b>	<b>O</b>		<b>0</b>	<b>.</b>	<b>0</b>	<b>0</b>	<b>0</b>			<b>0</b>	<b>.</b>	<b>0</b>	<b>0</b>	<b>0</b>		<b>P</b>	<b>O</b>	<b>L</b>

Allows establishing the size of the product pump.

The available sizes of proportioning product pump are marked in bold:

<b>PUMP SIZE</b>	<b>cm<sup>3</sup> moved in one cycle</b>	<b>PUMP SIZE</b>	<b>cm<sup>3</sup> moved in one cycle</b>	<b>PUMP SIZE</b>	<b>cm<sup>3</sup> moved in one cycle</b>
<b>0.3</b>	<b>30.0</b>	<b>0.88</b>	<b>86.4</b>	<b>1.2</b>	<b>118.7</b>
<b>0.4</b>	<b>39.3</b>	<b>0.9</b>	<b>94.8</b>	<b>2.0</b>	<b>196.6</b>
<b>0.6</b>	<b>59.4</b>	<b>1.0</b>	<b>98.8</b>		
<b>0.8</b>	<b>78.3</b>	<b>1.1</b>	<b>110.3</b>		

Use **UP/DOWN** to modify the pump size.

Once the requested value has been established, press **ENTER** to confirm and finalize the setup.



**Hydraulic Pumps Selection Screen**

		H	Y	D	R	A	U	L	I	C			P	U	M	P	S		
I	S	O		0	0								0	0			P	O	L

Allows establishing the size of the hydraulic pump.

The flashing value can be modified using **UP/DOWN** or entering the new value from the numeric keypad. Use **RIGHT/LEFT** to go from one product to the other (ISO / POL).

Once the requested value has been established, press **ENTER** to confirm and finalize the setup.

**Alternative Heating Screen**

A	L	T	E	R	N	A	T	I	V	E		H	E	A	T	I	N	G	
									0	N									

**ON** alternative heating option can be selected to avoid the summing of the total power of the two heaters when the electric resistances (18 kW) are on. This way, the momentary total power of the heaters (9 kW) is reduced to the half.

Use **RIGHT/LEFT** to select mode and press **ENTER** to confirm and finalize the setup.

**Flow Meters Option Screen**

	F	L	O	W		M	E	T	E	R	S		O	P	T	I	O	N	
									0	N									

Allows establishing the working mode with or without **FLOW METERS**.

Use **RIGHT/LEFT** to select mode and press **ENTER** to confirm and finalize the setup.

**Serial Number Visualization Screen**

		S	E	R	I	A	L			N	U	M	B	E	R				
						0	0	0	0	0	0	0	0						

Allows visualizing the serial number of the proportioning unit.

**Master Menu Access Screen**

		G	A	M	A		M	E	N	U		A	C	C	E	S	S		
P	A	S	S	W	O	R	D	:	0	0	0	0	0						

**NOTE:** Only for the use of **HI-TECH SPRAY EQUIPMENT, S.A.**



Allows accessing the constants screen of the manufacturer through the introduction of a password.

The numeric interval of the password is between 00000 and 99999.

Enter the PASSWORD through the numeric keypad and press **ENTER** and **MODE**.

**Probe Calibration Screen**

	P	R	O	B	E			C	A	L	I	B	R	A	T	I	O	N	
								O	N										

This screen must be activated every time that a probe calibration needs to be done. Select **ON** to activate the screen and **OFF** to deactivate it.

Use **UP/DOWN** to select one of the two options and press **ENTER** to confirm the setup.

**Probe Calibration Screen**

	P	R	O	B	E			C	A	L	I	B	R	A	T	I	O	N	
I	S	O	:	0	0		T	M	P	:	0	0		P	O	L	:	0	0

The procedure for the heater probes and the cold union is made through direct comparison with the known room temperature.

Use **UP/DOWN** to increase or decrease the temperature of the cold union in the electronic card (TMP), in the Isocyanate (ISO) heater probe and the Polyol (POL) heater probe, or else introduce the new value from the numeric keypad.

Once the requested value has been established, press **ENTER** to confirm and finalize the setup.

Use **LEFT/RIGHT** to go from one value to another.

**NOTE:** Ensure that the hoses are totally depressurized when making the calibration.

**Internal Clock Adjustment Screen**

I	N	T	.	C	L	O	C	K		A	D	J	U	S	T	M	E	N	T
										0	0								

Allows establishing the timing of the internal clock of the CPU, valid for the processing of the different parameters in the screen.

**Impulses/Litre Selection Screen**

			I	M	P	U	L	S	E	S	/	L	I	T	R	E			
I	S	O		0	0	0	0					0	0	0	0		P	O	L

Allows establishing the impulses per litre of the flow meter so that the CPU can do the corresponding processing.

The range of selection goes from 1 to 9,999 impulses, with rises of 1 impulse.



Service Manual

The flashing value can be modified using **UP/DOWN** or entering the new value from the numeric keypad. Use **RIGHT/LEFT** to go from one product to the other (ISO/POL).

Once the requested value has been established, press **ENTER** to confirm and finalize the setup.

**Pressure Transducers Selection Screen**

T	R	A	N	S	D	U	C	E	R	S		P	R	E	S	S	U	R	E		
M	A	X	:	0	0	0													b	a	r

Allows establishing the maximum value of the pressure range of the transducers.

The range of selection goes from 1 to 999 bar, with rises of 1 bar. Use **UP/DOWN** to increase or decrease the pressure, or else introduce the new value from the numeric keypad.

Once the requested value has been established, press **ENTER** to confirm and finalize the setup.

**Proportionality Constant Selection Screen**

	P	R	O	P	O	R	T	I	O	N	A	L		V	A	L	U	E		
P	I	D	:	0																

Allows establishing the proportionality constant for the automatic control system in the temperature of the heaters (PID). Use **UP/DOWN** to increase or decrease the value, or else introduce the new value from the numeric keypad. Once the requested value has been established, press **ENTER** to confirm and finalize the setup.

**Integration Constant Selection Screen**

			I	N	T	E	G	R	A	L		V	A	L	U	E			
P	I	D	:	0															

Allows establishing the integration constant for the automatic control system in the temperature of the heaters (PID). Use **UP/DOWN** to increase or decrease the value, or else introduce the new value from the numeric keypad.

Once the requested value has been established, press **ENTER** to confirm and finalize the setup.

**Derivation Constant Selection Screen**

			D	E	R	I	V	A	T	I	V	E		V	A	L	U	E	
P	I	D	:	0															

Allows establishing the derivation constant for the automatic control system in the temperature of the heaters (PID). Use **UP/DOWN** to increase or decrease the value, or else introduce the new value from the numeric keypad.

Once the requested value has been established, press **ENTER** to confirm and finalize the setup.



## ALARMS

When the unit has faults caused by conditions affecting its correct operation, an audible alarm will sound and a screen will show the alarm that has occurred. The system does not allow an alarm to be reset until the fault causing the alarm has been corrected. After resetting, **RESET** must be pressed to re-establish the system.

The procedures recommended to determine the possible causes activating the alarms are indicated in the following:

### Frequency Converter Alarm Screen

F	R	E	Q	U	E	N	C	Y			C	O	N	V	E	R	T	E	R
I	S	O					A	L	A	R	M						P	O	L

Will show in the following scenarios:

- When some internal operation inaccuracy is detected by the frequency converter
- When there is not enough electrical feeding power arriving to the converter, after the POWER CONTROL key has been pressed
- When an overcharge of electrical intensity is produced in either of the two motors which turn the hydraulic pumps on

### Over-pressure Alarm Screen

			H	I	G	H			P	R	E	S	S	U	R	E			
I	S	O					A	L	A	R	M						P	O	L

Will show:

- When an excess of pressure in either of the circuits ISO/POL is produced (safety pressure switches contacts separated)

### Heaters High Temperature Alarm Screen

			H	E	A	T	E	R		H	I	G	H		T	E	M	P	.		
I	S	O					A	L	A	R	M						P	O	L		

Will show:

- When an excess of temperature in either of the circuits ISO/POL is produced (safety thermostats contacts separated)

### Out of Tolerance Flow Alarm Screen

O	U	T				T	O	L	E	R	A	N	C	E			F	L	O	W	
I	S	O					A	L	A	R	M						P	O	L		

Will show:

- When FLOW CONTROL key is activated and the ISO and POL flow is out of the established tolerance



Out of Tolerance Pressure Alarm Screen

O	U	T		T	O	L	E	R	A	N	C	E		P	R	E	S	S	.
I	S	O				A	L	A	R	M							P	O	L

Will show:

- When PRESS CONTROL key is activated and the ISO and POL pressure is out of the established tolerance

Out of Tolerance Hose Temperature Alarm Screen

O	U	T		T	O	L	E	R	.	H	O	S	E		T	E	M	P	.
I	S	O				A	L	A	R	M							P	O	L

Will show:

- When TEMP CONTROL key is activated and the ISO and POL temperature in the hoses is out of the established tolerance

Empty Material Drum Alarm Screen

E	M	P	T	Y		M	A	T	E	R	I	A	L			D	R	U	M
I	S	O				A	L	A	R	M							P	O	L

Will show:

- When the material drums screen is activated and either of both products remains without material

Heater Temperature Probe Failure Alarm Screen

				H	E	A	T	E	R			P	R	O	B	E			
I	S	O				A	L	A	R	M							P	O	L

Will show:

- When the ISO or POL heater temperature probe has some fault
- The temperature visualization display will show (---)

Hose Temperature Probe Failure Alarm Screen

				H	O	S	E			P	R	O	B	E					
I	S	O				A	L	A	R	M							P	O	L

Will show:

- When the ISO or POL hose temperature probe has some fault
- The temperature visualization display will show (---)
-

## METHOD OF THREADED UNION OF THE HOSES

Follow the torques for threaded joints listed in **Table 1** according to thread sizes of hose fittings to ensure their proper assembly.

There is also an alternative procedure to obtain an equivalent torque without using special tools: joint both ends of the hoses to be connected, tighten a swivel nut by hand (without using spanner) until there resistance on the nut. Fit two spanners (1) on the fixed ends of the hoses and turn the swivel nut with a third spanner (2) as many flats from wrench resistance (FFWR) as indicated in **Table 1**.

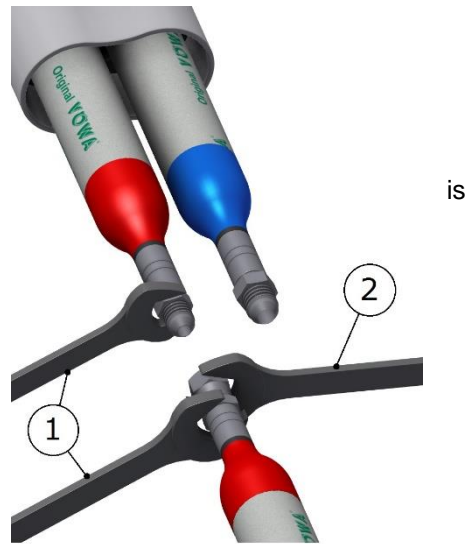
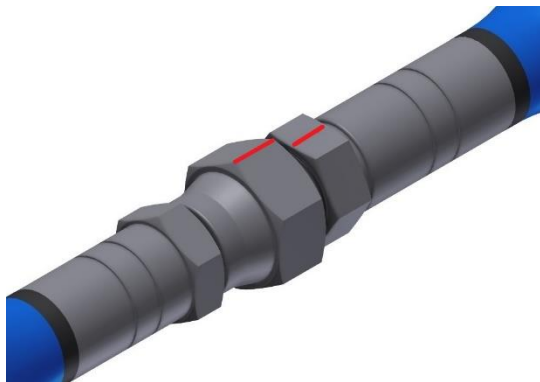

Table 1. Tightening Threaded Joints		
THREAD SIZE	TORQUE Nm	FFWR
1/2"-20	23	2 (or 120°)
9/16"-18	30	1-1/2 (or 90°)

**NOTE:** 1 FFWR corresponds to one complete shear of a flat marked with red between swivel and fitting or else 60°.







**Disconnect the unit from the main power supply before working on the inside of the electrical console. The electrical maintenance of the machine must only be performed by a qualified electrician.**

## INSTALLATION

**CAUTION!** Use suitable protection and follow the recommendations in the safety information provided by product suppliers when installing or working with the unit.

**HI-TECH** provides a series of tools and accessories necessary for assembling the machine. The kit is made up of the following elements:

REFERENCE	DESCRIPTION	QTY.
BI-00009	Tube of grease Lubriplate 1.75 oz./ 49 gr	1x
NR-00014	Parts Identification Manual	1x
NR-00015	Service Manual	1x
NR-00065	Monobloc Pumps Parts Manual	1x
HT-00001	Magnet holder tools	1x
HT-00003	Pin extractor	1x
MA-00102	12" Hoses Connection Cover	2x
EM-00012	Hose TCS packaging	1x
EL-00093-01	White Flange 300 x 4.8	3x
HT-00045	Allen key 1/8"	1x
EL-00100-06	Blue Terminal for Cable 16 mm <sup>2</sup> L=12mm	4x
TN-00242	Threaded Rod 1/4"-20 UNC x 14" nylon	4x
EL-00052-00	ISO – POL TCS Assy	1x



**Inside the console there is a terminal strip for connecting the principal electrical wire (not supplied) to the unit. The electrical connection of the unit must only be carried out by a qualified electrician.**

**NB:** To ensure that the unit works correctly, the electrical supply must meet the specifications indicated on page 6 of this manual and appearing on the machine specifications plate.

Follow the recommended procedure in the indicated order to install the unit:

- a) Insert the main power cable by passing it through the wire stop at the bottom of the electrical console and connect as shown in the diagram.

Use the proper size of cable according to the voltage, current and maximum power required by the Unit.

**The sizing of the cable is calculated for a length of 25m, for longer lengths you must recalculate the appropriate section.**



Motors 3 kW	Motors 4 kW
54,0 A @ 3PE~400V	62,0 A @ 3PE~400V
Cable Section 10 mm <sup>2</sup>	Cable Section 10 mm <sup>2</sup>

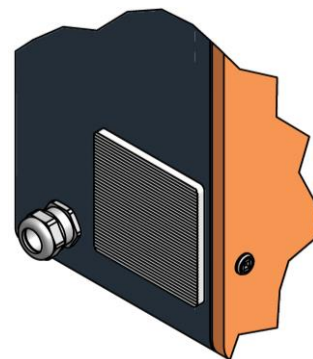

**NOTE:** Make sure the power cable is disconnected from the mains source before connecting it to the terminal strip in the console. It is compulsory to connect the unit to an ground connection. The unit features a control circuit that verifies the inlet voltage and the presence of the three phases. Once the control is made, it allows voltage to arrive to the power supply.

- b) Load 100 litres (26 gal) of hydraulic fluid into the tank of the unit. The oil must be of the characteristics and specifications of DIN 51524 standard, sections 1 and 2 (for example. ISO VG 46).

**NB:** Do not fill the tank to maximum capacity (128 Lts – 34 gal); make sure the amount of oil is not more than 80% of its maximum capacity (100 Lts. – 26 gal). Use the visual level indicator of temperature on the tank as a reference, because the maximum temperature limit (80°C – 176°F) coincides with the advised capacity.

- c) Fill the lube reservoir of the Isocyanate pump with DOTP. It is not necessary to prime the system.
- d) Connect the hoses of the products to the outlets of the respective flow meters (the Polyol hose to the Polyol flow meter and the Isocyanate hose to the Isocyanate flow meter).

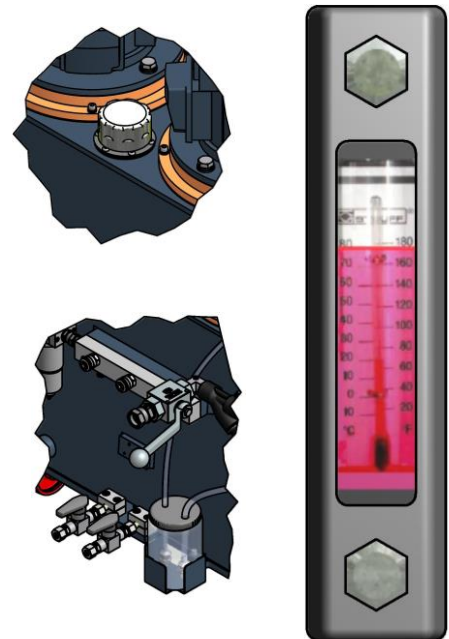

**NB:** The product hoses have been identified with red (Isocyanate) and blue (Polyol), enabling them to be rapidly distinguished. To avoid errors in connecting the coupling connectors of the Isocyanate and Polyol hoses, the connectors are of different sizes to make it impossible for connections to be swapped.

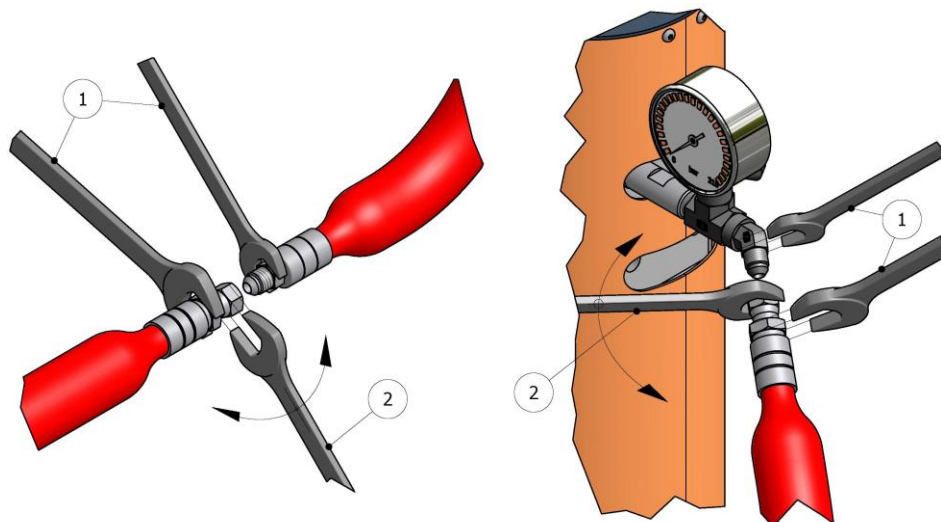

**Figure 1. Method of union of the Hoses**

**WARNING!** To join the hoses together or to connect them to the heaters or the gun, use two spanners to hold the parts to be joined (1) and a third spanner to tighten or loosen the connecting nut (2) as shown in the illustrations in Figure 1. The connections must be tightened to a torque indicated in Table 1 in pg.32.

The hoses receive vacuum drying treatment and are supplied interconnected at the ends to prevent them from absorbing moisture. Do not separate them until they are going to be installed in the unit.

The hose connection system includes special terminals (fast lock) to facilitate the electrical connection to the transformer and between the different sections installed in the unit.

The transformer offers the option of connecting to a 45 V output voltage valid for a total hose length of up to 48 meters (158 ft), or an output voltage of 90 V, for hose lengths of over 48 meters (158 ft); connect to one output voltage or the other depending on the total hose length installed. Before starting up the unit, make sure that the connection made in the factory adapts to the total length of hose installed. If you add or eliminate sections of hose, make sure the output voltage of the transformer to which it is connected is suitable for the resulting total length. Otherwise, change the connection.

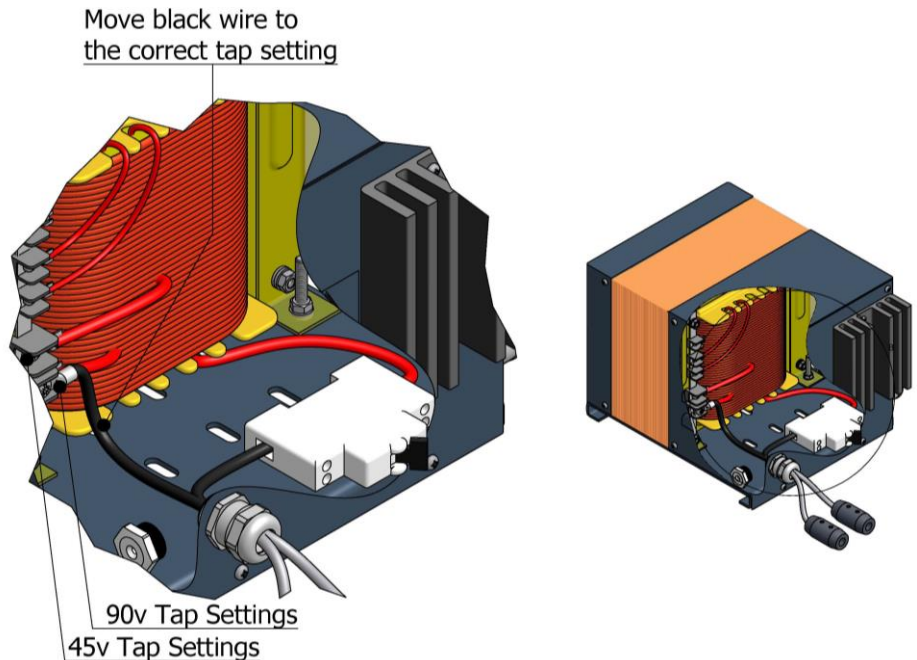

- e) Connect the wires of the heated hoses system of the products to the “fast lock” connector coming out of the hose transformers as follows:
  - a. Unscrew the Nylon Safety Plug from the “fast lock” connector body.
  - b. Unscrew partially the Socket Head Set Screw from electrical wires.
  - c. Insert the heated hose electrical wire with terminals into the “fast lock” connector body.
  - d. Tighten the Socket Head Set Screw of the terminals and place the Nylon Safety Plugs.

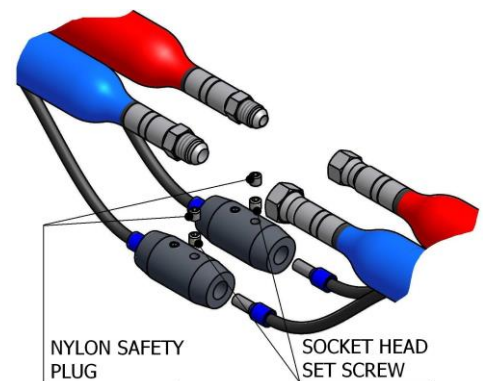

Repeat the same steps to connect the “fast lock” that you will find in the middle hose connections

- f) Connect the rest of the product hoses to complete the required total length.
- g) Remember that the hoses are identified with red (Isocyanate) and blue (Polyol).
- h) Connect the magnetic sensor wire connector to the output connector of the unit.
- i) Make the connection between the rest of the wire sensor connectors, up to the gun connector so the total length is completed.

**NB:** Assure the proper mechanical and electrical connection of the hoses to avoid possible product leakage and hose heat problems.

- j) Install the probe of control of temperature TCS between the last stretch of hose of product and the final stretch connected to the gun. Stretch carefully the cable of the probe inserting it in the Isocyanate hose and in that of Polioli respectively.
- k) Wind the connectors of the probes to the connectors of the hose. Realize so many connections as stretches of 15 m hose you have.
- l) Realize the connections between the connectors of exit of the probes TCS of the first stretch of hose and the connectors proceeding from the machine.
- m) As soon as the connections were completed, place the protections for the union fixing them with three plastic bridles. Later cover the union with the ends of the cases.

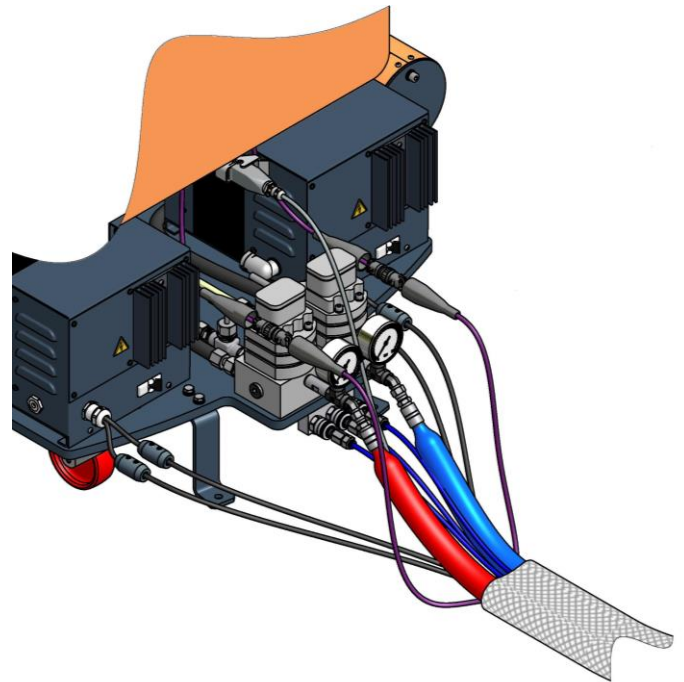
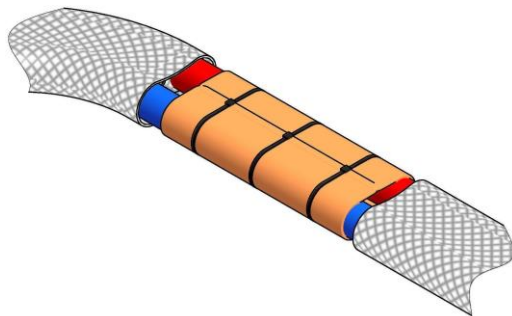
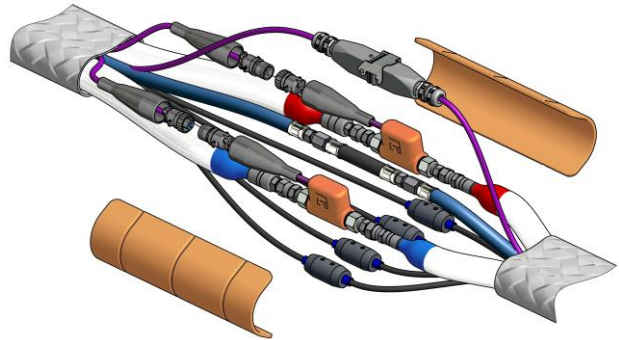

**NB:** To protect the TCS sensor, you must pay special attention not to kink or excessively bend the hoses. Do not roll up the hoses with a radius of under one meter / 3 feet.

- n) Connect the air hoses.
- o) Connect the hoses to the connectors of the coupling block of the gun, making sure that the manual valves are closed.

Proceed to install the transfer pumps paying special attention to connect each pump to “its” respective product, as changing the pumps would cause a reaction in the products inside them and make them useless. Identifying each pump with a tape of the same color as that of the hoses (blue for the Polyol pump and red for the Isocyanate pump) might be a good method for avoiding errors in connection.



Do the following steps to install the pumps:

- a) Make sure that the inlet valves of the products to the unit are closed.
- b) Connect one end of the Polyol hose (3/4" thread) to the Polyol valve and the other end to the transfer pump of the same product.
- c) Connect one end of the Isocyanate hose (3/4" thread) to the Isocyanate valve and the other end to the transfer pump of the same product.
- d) Connect the air hose to the transfer pumps.
- e) Install the unit ground connection. The movement of the product inside the hose can cause static electricity and produce electrical discharges.

Before using the unit, the residual air and oil from factory testing must be eliminated. To purge the whole circuit, proceed as follows:

- f) Pressurize the transfer pumps and open the inlet ball valves. Make sure there are no leaks.
- g) Turn the general switch ON. The top pilot light will come on.

**NB: After the general switch has been turned on, wait for 2 seconds before the feeding supply arriving into the unit stabilizes.**

- h) Press the POWER CONTROL key. The top led in the key will light on.  
Hold the coupling block with the outlet of each product in separate vessels and open the manual valves of each product. The capacity of the vessels must be of approximately 3 liters.
- i) Keep pressing the ISO PRESS key to pressurize the Isocyanate circuit up to 100 bar approximately.

**NB: The maximum pressurization pressure will be established as the maximum value in the ISO pressure screen.**

Keep pressing the POL PRESS key to pressurize the Polyol circuit up to 100 bar approximately.

**NB: The maximum pressurization pressure will be established as the maximum value in the POL pressure screen.**

- j) Press the ISO PUMP key to start the engine. The top led of the key will light on.
- k) Press the POL PUMP key to start the engine. The top led of the key will light on.

Allow the materials to come out of the coupling block until the residual oil and the air bubbling has disappeared completely. (approximately 2-3 liters)

- l) Close the manual valves of each product and clean the coupling block of the remains of product.
- m) Pressing the ISO PRESS and POL PRESS keys, slowly increase the pressure of the products to check for product leaks in the hose joints. Retighten if necessary and tape the connectors to protect them from possible damage.

**NB: The maximum pressurization pressure will be established as the maximum value in the ISO and POL pressure screens.**

- n) Press the ISO PUMP key to stop the engine. The top led of the key will go out.
- o) Press the POL PUMP key to stop the engine. The top led of the key will go out.
- p) Place the gun in the coupling block.



## START - UP PROCEDURES

For the start-up, follow the recommended procedure in the indicated order.

**CAUTION!** *The start-up procedure described next must be started only after all the temperature, pressure and remaining parameter values have been correctly established in the corresponding screens.*

- a) Check the state of the DOTP plasticizing oil in the lubrication tank of the Isocyanate pump. Change the oil if you see changes in the color or signs of solidification.
- b) Check the hydraulic oil level. Add oil if the level is low.
- c) Make sure that the chemical products to be processed are above the minimum temperature required to be supplied to the unit through the transfer pumps. Ask your product supplier for information on the minimum supply temperature.
- d) Check the input filters of the products. Clean them if necessary.
- e) Pressurize both transfer pumps and open the inlet valves of the products to the unit.
- f) Ensure that the emergency push-button is not activated.
- g) Turn the general switch ON.
- h) Press the POWER CONTROL key. The top led will light.
- i) Press the ISO key under the HOSES display. The top led of the key will light. Once the product has reached the set temperature the led will flash.
- j) Press the POL key under the HOSES display. The top led of the key will light. Once the product has reached the set temperature the led will flash.
- k) Press the ISO key under the HEATERS display. The top led of the key will light. Once the product has reached the set temperature the led will flash.
- l) Press the POL key under the HEATERS display. The top led of the key will light. Once the product has reached the set temperature the led will flash.

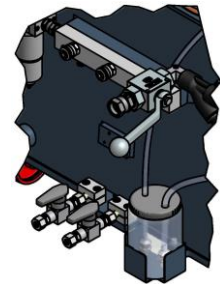

**CAUTION!** *To avoid excessive pressure in the heating hoses, wait for the product in them to reach the required temperature before starting up the hydraulic system.*

- m) Press the ISO PRESS key to pressurize the Isocyanate circuit to the required working pressure.

**NB:** *The maximum pressurization pressure will be established as the maximum value in the ISO pressure screen.*

- n) Press the POL PRESS key to pressurize the Polyol circuit to the required working pressure.

**NB:** *The maximum pressurization pressure will be established as the maximum value in the POL pressure screen.*

- o) Press the ISO PUMP key. The top led of the key will light. The Isocyanate proportioning pump will move alternatively.
- p) Press the POL PUMP key. The top led of the key will light. The Polyol proportioning pump will move alternatively.



Check the pressure of each proportioning pump on their respective gauges on the heater outlet. The pressures must be practically the same and remain constant. If the pressures fluctuate, consult the fault section before continuing.

- q) Connect the air supply to the gun; open the manual valves of each product; make a test projection and check the pressures on the product gages. Should the projection test be correct and the pressures remain equal, proceed with the application.





## SHUTDOWN PROCEDURE

Follow the recommended procedure in the indicated order for machine shut down when work is stopped for the day.

- a) Press the ISO PUMP key. The top led of the key will go out.
- b) Press the POL PUMP key. The top led of the key will go out.
- c) Use the gun to project into a waste container until the pressure of the products decreases to around 30 bar and the spray pattern starts to fall.

***CAUTION!*** To avoid possible product leakage and the early failure of the pump seals, the pressure must not be reduced to zero. It is recommended to keep the system with a minimum pressure of 30 bar to extend the life of the seals.

- d) Press the ISO and POL keys next to the heater temperature displays. The two leds will go out.
- e) Press the ISO and POL key under the HOSES display. The led will go out.
- f) Press the POWER CONTROL key. The led will go out.
- g) Turn the general switch OFF.
- h) Close the product inlet ball valves.
- i) Disconnect the air supply to the transfer pumps.
- j) Disconnect the magnetic switch of the gun.
- k) Close the manual valves of the coupling block and dismantle the gun to carry out the corresponding maintenance.



## CLEANING PROCEDURE

**CAUTION!** *The unit includes components that reach temperatures that are liable to cause burns. The hot parts of the unit must not be handled until they have cooled.*

To avoid possible contamination, the circuits of the unit must previously be cleaned (pumps, heaters and hoses) whenever applications have to be made that require a change of components.

Follow the recommended procedure in the order indicated to perform the cleaning when you have to change the components of the system:

- a) Place two drums of DOTP cleaning agent close to the machine.
- b) Dismantle the gun and leave the coupling block connected to the hoses.
- c) Remove the transfer pumps of the product drums and place them in the drums of the DOTP cleaning agent.
- d) Place a vessel under the coupling block to gather up the products contained inside the machine.
- e) Open the manual valves on the coupling block.
- f) Turn the general switch ON.
- g) Press the POWER CONTROL key. The top led of the key will light.
- h) Press the ISO PRESS key and keep pressing it you see that only DOTP cleaning agent comes out free of impurities.
- i) Press the POL PRESS key and keep pressing it you see that only DOTP cleaning agent comes out free of impurities.
- j) Close the valves on the coupling block and press the POWER CONTROL key. The top led of the key will go out.
- k) Place the transfer pumps in the drums of the new products.
- l) Place a vessel under the coupling block to collect the DOTP cleaning agent.
- m) Open the valves on the coupling block.
- n) Press the POWER CONTROL key. The top led of the key will light on.
- o) Press the ISO PRESS key and keep pressing it you see that only the new product comes out.
- p) Press the POL PRESS key and keep pressing it you see that only the new product comes out.
- q) When the products come out without the contamination produced by the effect of the DOTP cleaning agent, the cleaning process is complete and you can proceed as normal.



## LONG TERM SHUTDOWN PROCEDURES

**CAUTION!** *The unit includes components that reach temperature that are liable to cause burns. The hot parts of the unit must not be handled until they have cooled.*

When you plan to shut down the machine for more than FOUR weeks, the products contained in the machine must be replaced by DOTP plasticizing agent.

Follow the recommended process in the order indicated, to change the products for DOTP oil:

- a) Place two drums of DOTP cleaning agent close to the machine.
- b) Dismantle the gun and leave the coupling block connected to the hoses.
- c) Remove the transfer pumps of the product drums and place them in the drums of the DOTP cleaning agent.
- d) Place a vessel under the coupling block to gather up the products contained inside the machine.
- e) Open the manual valves on the coupling block.
- f) Turn the general switch ON.
- g) Press the POWER CONTROL key. The top led of the key will light.
- h) Press the ISO PRESS key and keep pressing it you see that only DOTP cleaning agent comes out free of impurities.
- i) Press the POL PRESS key and keep pressing it you see that only DOTP cleaning agent comes out free of impurities.
- j) Close the valves on the coupling block and press the POWER CONTROL key. The top led of the key will go out.
- k) Turn the general switch OFF.
- l) Disconnect the supply system of the transfer pumps and the process is finished. The proportioning pumps, the heaters and the hoses must be full of DOTP plasticizing oil. Never leave the machine or the hoses empty of product or DOTP plasticizing oil.

**NOTE:** *Never use liquids not recommended or not approved by HI-TECH. Never use approved liquids that have been contaminated with water or ISO/POL. If you are not sure in the quality of the liquid you are going to use we strongly recommend that you check the machine 2-3 times every 2 weeks after you have filled it by recirculating through heated hoses (see p. 42) with fresh plasticizer unless you make sure the liquid that comes out is completely pure and clean.*

## TROUBLESHOOTING

The **evolution VR** unit has been designed and built to withstand severe working conditions with a high degree of reliability, provided it is used suitably. This chapter contains information on possible faults that may prevent the continuation of work with the unit. The information provided must serve as guideline to detect and resolve the large majority of the problems before calling for the assistance of the authorized distributor or HI-TECH technical service. In any case, feel free to contact the technical assistance service of HI-TECH SPRAY EQUIPMENT S.A., where a qualified technician will advise you on whatever you may need.

**NB:** All repairs performed by unqualified personnel or the use of spares other than originals may cause damage to the unit and put the operator at risk.



*To prevent possible bodily harm caused by incorrect handling of the raw materials and solvents used in the process, carefully read the safety information provided by your supplier.*

*Deal with the waste caused according to current regulations.*



*Disconnect the unit from the power supply before carrying out any operation inside the electrical console.*

*The electrical maintenance of the machine must only be performed by a qualified electrician.*



*To avoid damage caused by the impact of pressurized fluids, do not open any connection or perform maintenance work on components subject to pressure until the pressures have been completely eliminated.*

*Use suitable protection when operating, maintaining or remaining in the operating area of the unit. This includes, but is not limited to, the use of face masks, protective goggles, gloves, shoes and safety clothing.*



*The unit includes components that reach temperature that are liable to cause burns. The hot parts of the unit must not be handled until they have cooled.*



*To prevent serious harm by crushing or loss of limbs, do not work with the unit without the safety duly installed on all moving parts. Make sure that all of the safety protections are correctly fitted after all repair or maintenance work.*



## Heaters

**WARNING!** Before resolving any kind of defect, make sure all of the push-buttons are off, that the general switch is in shutdown position and that the unit is disconnected from the power supply. Never handle the inside of the control panel with the unit connected to the power supply. The heaters are components that reach high temperatures; wait until they have cooled before handling.

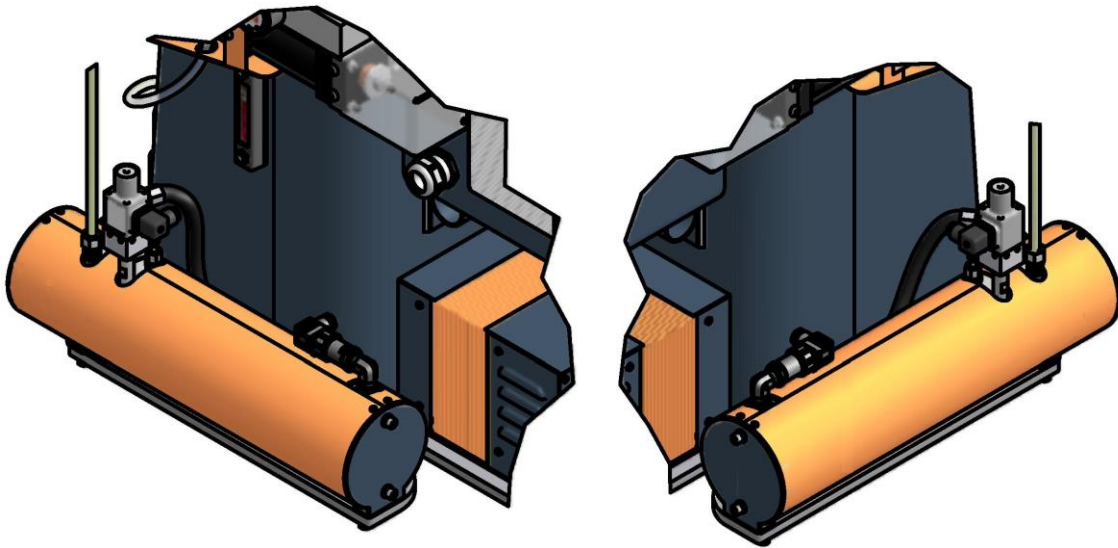

**NB:** The thermostat is a safety element in contact with the heater. If the temperature exceeds 120° C (248° F) the thermostat will cut off the electric supply by deactivating the POWER CONTROL. The thermostat will not reset until the temperature in the heater is below 120° C (248° F).

If the temperature in the Isocyanate heater or the Polyol heater is over 120° C (248° F), an audible alarm will be activated and the control panel will show the HEATER (ISO/POL) HIGH TEMPERATURE screen.

Follow the recommended procedure in the order indicated, to try to solve the problem and avoid costly repairs. Make sure all the automatic switches and control elements are in the correct working position before determining the existence of a fault.

### PROBLEMS

The heater fails to heat, the push-button led is lit.

The heater display shows the symbol (---)

### SOLUTIONS

#### 1. Static Relay

This determines that the static relay is not working when all of the previous checks have been correct.

### SOLUTIONS

1-2-3

4



## 2. Heating Resistances

Each heater has six 1250 W elements connected in parallel, which give the system a total power of 7500 W (optional 9000 W). If under normal conditions of ambient temperature, it is not possible to reach the temperature required in two or three minutes, it is possible that one or several heating elements are not working.

To check the state of the element, proceed as follows:

With the main switch off check with a tester that reading the total value of the heater resistance is indicated in the table according to the power, voltage and number for each installed heater elements, a higher value would indicate that one or more elements are faulty .

Disconnect them and check that the individual value of each element is as shown in the table according to the installed power and voltage.

**Table 2. Elements Values List**

(W)	(V)	x1 (Ω)	x2 (Ω)	x4 (Ω)	x6 (Ω)
450	230	117±2	58±2	29±2	19±2
900	230	58±2	29±2	14±2	9±2
900	400	177±2	88±2	44±2	29±2
1250	230	42±2	21±2	10±2	7±2
1250	400	128±2	64±2	32±2	21±2
1250	440	154±2	77±2	38±2	25±2
1500	230	35±2	17±2	8±2	5±2
1500	400	106±2	53±2	26±2	17±2
1500	440	129±2	64±2	32±2	21±2
1800	230	29±2	14±2	7±2	4±2
1800	400	88±2	44±2	22±2	14±2
1800	440	107±2	53±2	26±2	17±2
2000	230	26±2	13±2	6±2	4±2
2000	400	80±2	40±2	20±2	13±2
2000	440	96±2	48±2	24±2	16±2

Under extreme environmental conditions, the heater might be affected and fail to reach the required temperature. In this case, put the unit in a more favorable place, or use an auxiliary heating system.

## 3. Automatic Switch

This protects the elements against any possible change in voltage. With the general switch turned off, open the control panel and make sure the switch is activated (see electrical diagram), otherwise activate it.



#### 4. Temperature Probe

The control panel automatically detects any fault in the operation of the temperature probe. If the fault occurs, replace the probe, paying special attention not to damage it when assembling. The probe must be in firm physical contact with the heating element.



## Hose Heating

**WARNING!** Before resolving any kind of defect, make sure all of the push-buttons are off, that the general switch is in shutdown position and that the unit is disconnected from the power supply source. Never handle the inside of the control panel with the unit connected to the power supply. The hoses can reach high temperatures; wait until they have cooled before handling.

Follow the recommended procedure in the order indicated, to try to solve the problem and avoid costly repairs. Make sure all the automatic switches and control elements are in the correct working position before determining the existence of a fault.

### PROBLEMS

- The hose is hot, but fails to reach the selected temperature.
- The hose is not hot; the push-button led is lit.
- Only the sections of the hose closest to the unit are heated.
- The hose display shows the symbol (---).
- The automatic switch trips.

### SOLUTIONS

- 1-2-7
- 2-3-4-5
- 5
- 6
- 3

### SOLUTIONS

#### 1. Hose Length

The evolution VR unit has been designed to work with a maximum hose length of 93 meters (310 ft). A longer length will render the heating capacity less effective. Under extreme ambient conditions, the hose heating system may be affected and fail to reach the required temperature.

#### 2. Hose Transformer

The transformer offers the option of connecting to a 45 V output voltage valid for the connection of hose sections with a total length of up to 45 meters), or an output voltage of 90 V, for connecting hose lengths of over 45 meters; connect to either position depending on the total hose length installed in the machine. If the connection is performed incorrectly, the hoses will not reach the required temperature.

#### 3. Automatic Switch

This protects the secondary circuit of the transformer. The switch is located on the front of the transformer; make sure it is activated, otherwise activate it. Replace it with one of equal amperage if the switch fails to work correctly.

**CAUTION!** The replacement of the automatic switch with another of different characteristics may cause damage to the equipment and put the operator at risk.





#### 4. Triac

This determines that the triac is faulty when all of the previous checks have been correct. Replace the triac if it fails to work correctly.

#### 5. Hose Heating Components

- a) With the general switch turned off, make sure the hose connections and the electrical connections between the hoses and the unit are correct and tight. If the connections are correct and the hoses do not heat up, check section by section to locate the connection that is at fault.
- b) Proceed as follows:
- c) Disconnect the unit from the power supply by deactivating the general switch and start to check the hose section closest to the gun. Remove the "Fast Lock" connector, and make a "bridge" bypass on the connection immediately before.
- d) Restore the power supply, press the POWER CONTROL key and the ISO and RESIN keys under the HOSES display. If the heating works, the problem will be located in the last section of hose. Replace it. If not, follow these steps:
- e) Disconnect the unit from the power supply by deactivating the general switch, remove the "Fast Lock" connector from the second last section of hose and make a "bridge" bypass on the connection immediately before.
- f) Restore the power supply, press the POWER CONTROL key and the ISO and RESIN keys under the HOSES display. If the heating works, the problem will be located in the second last section of hose. Replace it. If not, repeat steps c) and d) until you find the point of the fault.

#### 6. TCS Temperature Control Probe

The control panel automatically detects any fault in the operation of the temperature sensor.

Should a fault be detected, an audible alarm will turn on and the control panel will show the alarm screen, ISO/POL HOSE PROBE.

To determine if the mistake is caused by the proper probe or by a defective electrical connection, realize the following cross-check: dismantling the electrical connector of the probe TCS of the last stretch of hose and without dismantling any other connection connect it straight to the electrical capture of the exit of the machine, if the control is restored check the electrical connections of the probe existing TCS in the intermediate stretches of the hoses, in the opposite case replace the probe TCS.

#### 7. Hose Heating Temperature Adjustment

The hose heating system maintains the temperature of the products coming through the heaters. This is the reason why the value set for the temperature of the hoses must be the same or 10°C less as that selected on the heaters display.

## Proportioning Pumps

**WARNING!** Before resolving any kind of defect, make sure all of the push-buttons are off, that the general switch is in shutdown position and that the unit is disconnected from the power supply source. Never handle the inside of the control panel with the unit connected to the power supply. The proportioning pumps are components that work under pressure; do not open any connection or perform repair or maintenance work on components subject to pressure until all of the pressures have been completely eliminated.

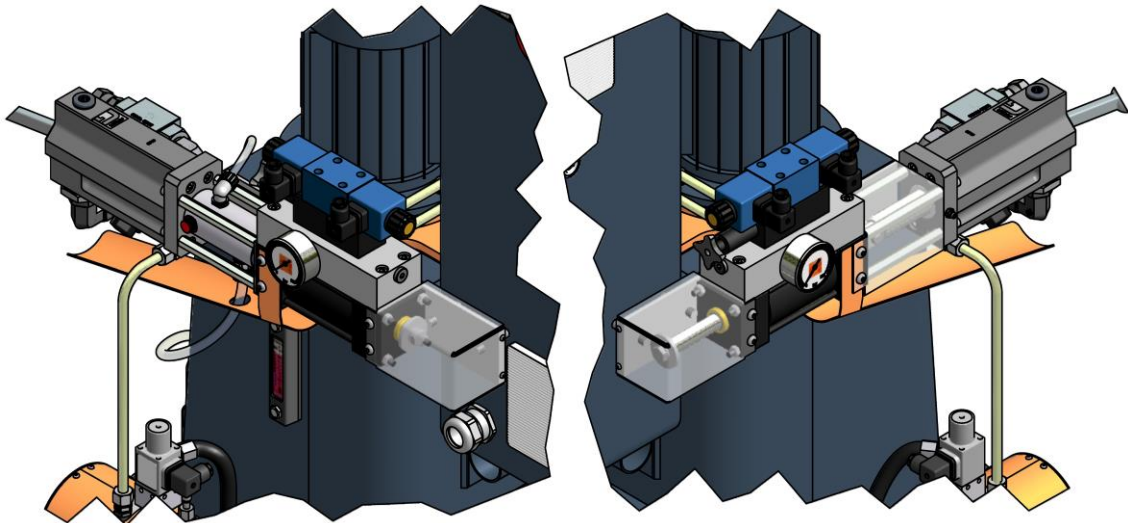

If excessive pressure is caused in the Isocyanate circuit or the Polyol circuit, an audible alarm will be activated, and the control panel will show the alarm screen ISO/POL HIGH PRESSURE.

Follow the recommended procedure in the order indicated, to try to solve the problem and avoid costly repairs. Make sure all the automatic switches and control elements are in the correct working position before determining the existence of a fault.

### PROBLEMS

### SOLUTIONS

The pumps fail to maintain the pressure when the unit is shut down.	1
There are pressure differences between the proportioning pumps.	1-2-3
There is cavitation in the proportioning pump.	1-2-3
The proportioning pumps do not change direction.	4
The proportioning pumps fail to move and the direction indicator lights are out.	4-5
The movement of the proportioning pumps is erratic.	4



## SOLUTIONS

### 1. Loss in the Ball Valves

Observe the pressure gauges to identify which pump fails to maintain the pressure and check in the solenoid of the solenoid valve which direction indicator light is on to determine in which direction the pump fails to maintain the pressure. If the lit lamp is the rear one, check the discharge valve ball of the pump.

If the lit lamp is the front one, check the suction ball valve.

Proceed as follows to check the valve balls:

- a) Disconnect the unit from the power supply and close both product inlet valves plus the supply system to the transfer pumps.
- b) Depressurize the proportioning pump and remove the corresponding ball valve.
- c) The loss from the valve ball is usually caused by foreign particles that prevent the perfect coupling of the ball with the ball seat. Clean the ball and the seat and make sure there are no faults from knocks, marks or scratches to the seat or the ball. Should the cleaning fail to resolve the problem or any fault be observed, replace the seat and the ball.

### 2. Unbalanced Pressures

Pressures are unbalanced when there is an obstruction in the hose or in the gun that prevents one of the components from coming freely through the gun chamber when spraying. Or when a problem in the pumping system prevents one of the components reaching the gun in the required amount.

It is relatively easy to identify which component is problematic, if we bear in mind that the chemical components used in the Polyurethane foaming are of a different color. By observing the color of the material that comes through the gun, we can determine which component is missing.

To determine whether the unbalancing is caused as a result of an obstruction or as a consequence of a problem in the pumping system, spray with the gun, observe the pressure indicated on the corresponding pressure gauge to the missing component and compare it with the pressure indicated by the gauge to the other component: if the pressure of the missing component is higher, the unbalancing is the result of an obstruction. Should the pressure be lower, the unbalancing is the consequence of a problem in the pumping system.

### 3. Cavitation

Cavitation occurs when the proportioning pump requires a larger volume of material than that supplied by the feeding system, causing the formation of a vacuum in the inlet of the proportioning pump. The causes of cavitation are the following:

- a) The transfer pump fails to supply the necessary volume. The problem might be in the pump not meeting the required specifications, in the lack of air supply to the pump or that the pump is faulty. A pump is recommended with a ratio of 2:1 for transferring the Isocyanate and a supply hose with an interior diameter of at least 20 mm.
- b) High viscosity. The polyurethane foaming systems normally require a minimum transfer temperature of 12° C; at lower temperatures, the product increases its viscosity, making the pumping more difficult. When the ambient conditions prevent the products from being maintained at a minimum temperature of 12° C auxiliary heating elements must be used to condition the products as the minimum temperature required for the transfer.
- c) The product inlet filter is obstructed (see Maintenance).
- d) The suction ball valve has leaks as a result of wear or possible faults in the ball or the closing surface of the seat, which means that part of the material supplied returns to the supply tank and that the proportioning pump supplies a smaller volume of material in the discharge cycle, causing an incorrect ratio.



#### 4. Fault in the Reversing Switch

The proportioning pump system has a plate that activates the reversing switches to carry out the change of direction.

A fault in the movement of the directional valve will cause the activation plate to pass over the switch and not make the change of direction. Proceed as follows to solve this problem:

- a) Determine the direction in which the plate must move; this depends on which switch has been passed over.
- b) Locate the slide for the manual activation of the directional valve in the hydraulic distributor: this is located at the same side of the machine towards which the activation plate must work.
- c) Turn the general switch ON, press the POWER CONTROL key and the ISO PUMP and POL PUMP keys. With the manual valves of the coupling block open, point the gun at a waste container.
- d) Press the manual slide of the directional valve and hold it until the activation plate is centered between the two run end reversing switches.
- e) If when pressing the slide, it moves freely, the excess run is due to an electrical problem. Press the POWER CONTROL key and the ISO PUMP and POL PUMP keys, approach a metallic body (e.g. the tip of a screw driver) to the front of the switches and observe if the change of the solenoids and the change of the direction indicator lights is produced: if the solenoids are not changed or the direction indicator lights fail to come on, there is an electrical problem in the run end micro or in the solenoid of the directional valve.

#### 5. Safety Pressure Switches

Each proportioning pump is protected by a safety pressure switch factory set at a limit pressure of 300 bar. When the limit pressure is reached, the pressure switch interrupts the electrical supply to the directional valve, stopping the pumps.

An alarm will be activated and the control panel will show the ISO/POL HIGH PRESSURE alarm screen.

When the pressure reaches lower values than the established limit, the proportioning pumps will restart. However, the causes of the excess pressure must be determined and corrected.



## Hydraulic Unit

**WARNING!** Before resolving any kind of defect, make sure that all of the push-buttons are off, the general switch is in shutdown position and the unit is disconnected from the power supply. Never handle the inside of the control panel with the unit connected to the power supply. The hydraulic unit is a component that works under pressure; do not open any connection or carry out maintenance work on components subject to pressure until all of the pressures have been completely eliminated.

Follow the recommended procedure in the order indicated, to try to solve the problem and avoid costly repairs. Make sure all the automatic switches and control elements are in the correct working position before determining the existence of a fault.

### PROBLEMS

The electric motor does not start or stops while it is working.  
 The hydraulic pump fails to develop pressure.  
 Little or no pressure with screeching.

### SOLUTIONS

1  
 2  
 2-3

### SOLUTIONS

#### 1. Frequency Converter

Should the electric motor draw excessive current, it will stop and the frequency converter will warn with an alarm.

Press the POWER CONTROL key, allow the motor to cool down, wait for the frequency converter to reset and press the POWER CONTROL key again so that the motor is operational again.

It is paramount to determine the reason why the motor has been subject to an overload. Should the frequency converter fail, the electric motor may be damaged due to overheating.

#### 2. Little or No Pressure

The most likely cause for no pressure is usually a deficient supply of the hydraulic fluid to the pump. This can be provoked by incorrect priming, a lack of hydraulic fluid or dirt in the suction filter. Check the indicated points to guarantee correct functioning.

#### 3. Noises

A noise similar to screeching is a symptom of cavitation. The noise is normal if it occurs during the start-up and lasts for approximately thirty seconds.

Should the noise continue, stop the machine to protect the hydraulic pump and make sure that the connectors are tight and that the pump has been correctly primed.

Another possible cause of noises in the pump is excessive temperature in the hydraulic oil. Make sure the oil supply is correct, and, if necessary, improve the ventilation to allow better spreading of the heat inside the hydraulic tank.

## MAINTENANCE

To achieve maximum output from your **evolution VR** unit, several daily or periodical maintenance operations are needed.



***To prevent possible bodily harm caused by incorrect handling of the raw materials and solvents used in the process, read carefully the safety information provided by your supplier.***

***Deal with the waste created according to current regulations.***



***Disconnect the unit from the power supply before carrying out any operation inside the electrical console.***

***The electrical maintenance of the machine must only be performed by a qualified electrician.***



***To avoid damage caused by the impact of pressurized fluids, do not open any connection or perform maintenance work on components subject to pressure until the pressures have been completely eliminated.***



***Use suitable protection when operating, maintaining or remaining in the operating area of the unit. This includes, but is not limited to, the use of face masks, protective goggles, gloves, shoes and safety clothing.***

***The unit includes components that reach temperature that are liable to cause burns. The hot parts of the unit must not be handled until they have cooled.***



***To prevent serious harm by crushing or loss of limbs, do not work with the unit without the safety duly installed on all moving parts. Make sure that all of the safety protections are correctly fitted after all repair or maintenance work.***



## Heaters

**WARNING!** Before performing any maintenance work, make sure that all of the push-buttons are off, the general switch is in shutdown position and the unit is disconnected from the power supply source. Never handle the inside of the control panel with the unit connected to the power supply. The heater is a component that reaches high temperatures; wait until it has cooled before handling.

### 1. Heating Elements

To replace a faulty element, proceed as follows:

- a) Depressurize the unit, disconnect it from the power supply and remove the cover on the heater.
- b) Disconnect the heating element from the terminal block and with an appropriate spanner, loosen the element and remove it from its housing. Inspect the element; it must be smooth and shiny in appearance. If it is blackened or has material adhered, replace it.
- c) Check the new element with a tester: the reading of the value of the resistance must be as shown in Table 2 on pag.46.
- d) Apply Teflon or sealing paste to the thread and assemble the element into its housing.
- e) Reconnect the wires to the terminal block; make sure the connection is in parallel and fit the heater cover.

**NB:** If the heating element that has to be replaced is the one in contact with the temperature probe, remove the probe first.

### 2. Temperature Probe

The temperature probe is fixed to the connector with a ferule and a torque nut. Once inserted in its housing, the ferule forms to the probe and does not allow it to be relocated or moved. The location of the probe is very important and must be done correctly before fitting the torque nut.

- a) Depressurize the unit and disconnect it from the power supply. Check the torque of the body of the connector inserted in the heater to prevent leaks.
- b) Assemble the heating element.
- c) Insert the torque nut and the ferule in the probe and insert this in the connector body until it comes into positive physical contact with the heating element. Make sure the spring does not prevent the probe from making contact with the resistance.
- d) Hold the probe in place and tighten the torque nut.



## Hydraulic Unit

**WARNING!** Before performing any maintenance work, make sure that all of the push-buttons are off, the general switch is in shutdown position and the unit is disconnected from the power supply. Never handle the inside of the control panel with the unit connected to the power supply. The hydraulic unit is a component that works under pressure; do not open any connection or carry out maintenance work on components subject to pressure until all of the pressures have been completely eliminated.

The hydraulic unit must be serviced each year as indicated below:

- a) Depressurize the unit and disconnect it from the power supply. Clean the hydraulic tank lid to prevent foreign bodies from falling into the tank when the lid is removed.
- b) Remove the suction and pressure pipes from the hydraulic pump and the tank lid.
- c) Separate the lid and the suction pipe from the hydraulic tank. Inspect the bottom of the tank for sediments. Should sediment be present, the tank must be emptied completely and the bottom must be cleaned, eliminating all the sediment and filling it once more with new hydraulic fluid.
- d) Clean the suction and pressure pipes and their connections.
- e) Replace the oil suction filter.
- f) Fit the suction and pressure pipes in the tank and fix the lid. Connect the pipes to the hydraulic distributor.





## Proportioning Pumps

**WARNING!** Before proceeding with maintenance works, make sure that all push buttons are switched off, the general switch is in the off position, and the Unit is unplugged from the power supply. Never handle the control panel interior while the Unit is plugged into the electricity grid. Dosing pumps are components that work under pressure, do not open any connections or perform any repair or maintenance work on components submitted to pressure until all pressures have been completely released.

When the pump works properly, it is not uncommon for a small amount of resin to filter through the joints and reach the visible part of the pump axis. Periodically inspect the axis and clean the residue when dosing pumps are stationary and the machine is switched off.

Disassemble and clean the dosing pumps annually, despite no obvious signs of leaks. Use this time to completely replace the joints and bearings given that, if you reassemble an element that does not seem damaged, it can cause premature wear in the remaining components (the NR-00065 Components Manual includes the joint kits that correspond to each pump model and size). Pump distribution bases must also be inspected, checking that the ball valves show no signs of wear, dents or marks that affect the pump's proper operation.

Perform a daily inspection of the Isocyanate pump lubrication bowl and check the condition of the DOTP plasticiser oil it contains. Replace the oil when you observe colour changes or when it shows signs of solidification. If this circumstance persists, replace the isocyanate pump joints using the corresponding kit.



In cases where the machine is submitted to large workloads or special work conditions, disassemble, clean and replace the dosing pump joints every six months.

Inspect rods, pistons and inside the sleeves for marks or scratches that may cause leaks or premature damage to the joints.

Only qualified personnel will be authorised to replace dosing pump joints, since they have the required expertise to that effect.

**NOTICE:** Three special tools can be used to simplify the seal assembly. Tools A and B to insert the shaft seal into the seal housing and tool C for the packing retainer flange assembly insertion through the shaft (see Table 3 in pg.58).

**Table 3. Tools for shaft seal assembly**

	Tool (A)	Tool (B)	Tool (C)
			
#0.80 Pump	HT-00124	HT-00125	HT-00036
#1.20 Pump			HT-00035

### Seals assembly

PISTON SEAL

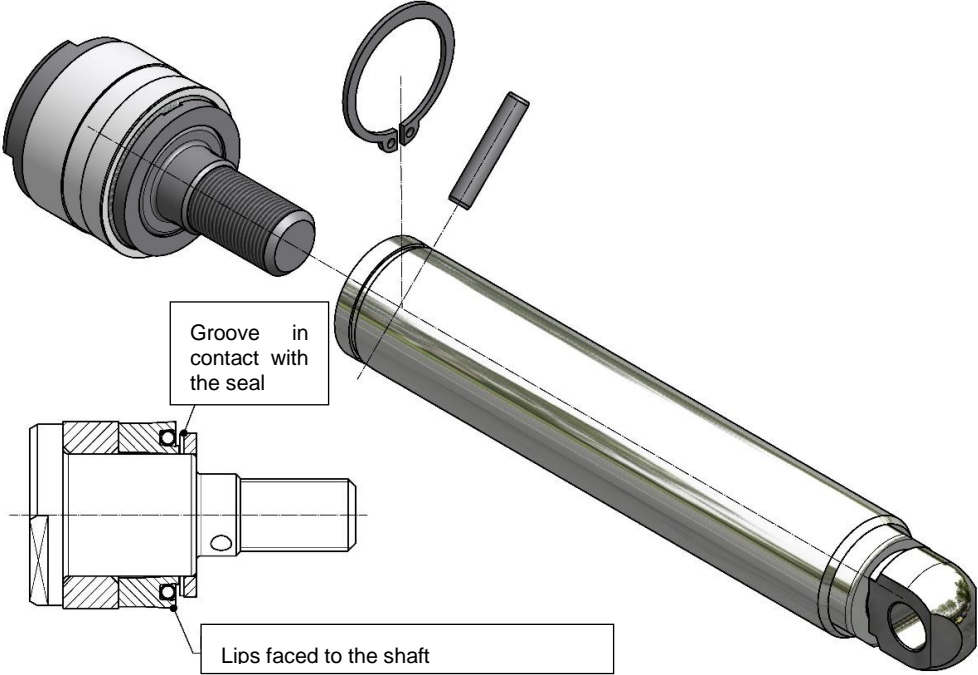

The diagram illustrates the assembly of a piston seal. It shows a piston shaft with a groove. A seal is being inserted into this groove. A spring pin is inserted into the shaft, and a snap ring is used to secure the assembly. Labels indicate that the lips of the seal should face the shaft and that the groove should be in contact with the seal.

<p>Insert the piston bearing, seal and washer into the piston shaft. Face the lips of the seal towards the end of the shaft. Face the grooves of the washer towards the seal.</p>	<p>Thread the plunger assembly onto the shaft as far as it will go (the pin holes in the shaft and plunger should line up).</p>	<p>Insert the spring pin so that it is recessed in the groove of the shaft. Insert the snap ring into the groove.</p>
---	---	---

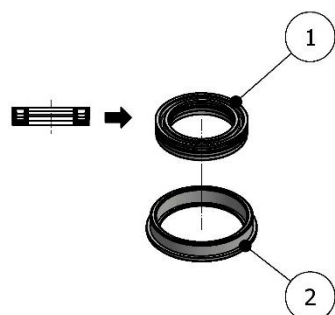
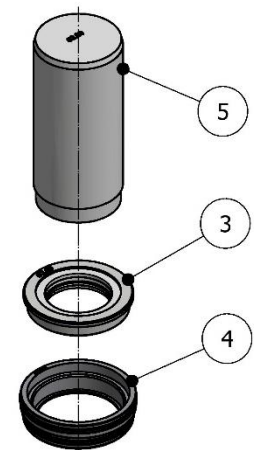
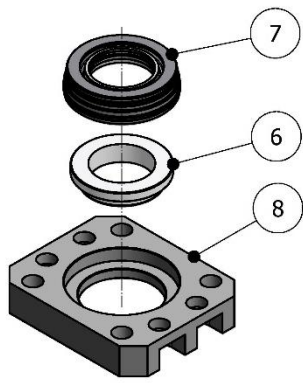
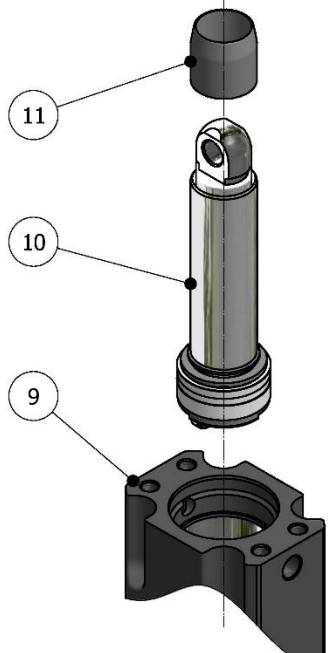
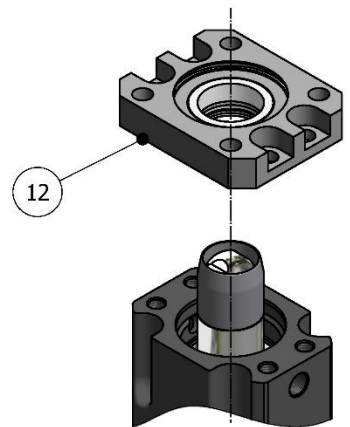
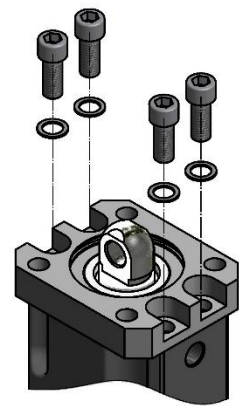
SHAFT SEAL		
		
<p>Insert the seal (1) into Tool A (2). Make sure that the lips are facing upwards.</p>	<p>Place tool A with the seal (3) inside the seal housing (4). With tool B (5) push the seal until it stops against the seal housing (4).</p>	<p>Place the shaft bearing (6) and the seal housing along with its corresponding O-rings (7) on the packing retainer flange (8).</p>
		
<p>Insert the shaft assembly (10) into the pump body (9) and place the tool C (11) on the tip of the shaft.</p>	<p>Mount the packing retainer flange assembly with all components assembled (12) on the front face of the pump. The shaft bearing should be visible from the outside.</p>	<p>Remove tool C and fix the packing retainer flange with its corresponding screws.</p>



## Product Inlet Filters

The filter bodies have a screen that prevents solid particles from entering the unit, thus affecting the correct functioning of the ball valve during the suction of the product. Inspect the filters each day as part of the machine start-up, and clean them. Replace the filter screen if necessary.

Isocyanate is a product that crystallizes with ambient moisture or freezing. If the storage and transfer is correct and the operating procedures are respected, the risk of contamination of the Isocyanate filter will be minimized.

***NB: Clean the Isocyanate inlet filter before the daily start-up; it should not be cleaned after the machine has been stopped for the day. Immediate spraying after cleaning the filter reduces the risk of moisture contamination or contamination through the reaction with the solvent used in the cleaning operation.***

To check the product inlet filters, proceed as follows:

- a) Disconnect the unit from the power supply and close the inlet valve from the filter you wish to check.
- b) Place a suitable vessel under the filter to collect the product coming out on removal. Carefully loosen the filter stopper to allow the product to be emptied into the vessel below. Completely unscrew the stopper.
- c) Remove the seal, the spring and the mesh and clean it all with the solvent used for cleaning the gun. Dry it all and check that the mesh is not obstructed. The holes in the mesh must be completely free. Replace the mesh if more than 10% of the surface is obstructed.
- d) Re-assemble the mesh, the spring and the seal. Screw on the stopper.
- e) Open the product inlet valve of the filter, make sure there are no leaks and proceed with the normal operation.



## *Isocyanate Pump Lubrication System*

Each day, inspect the lube reservoir of the Isocyanate pump and check the condition of the DOTP. Replace the oil when it shows changes in color or signs of solidification.

Oil solidification is the result of the absorption of moisture and the maintenance interval will depend on the working conditions. The closed circuit system reduces contamination.

Oil discoloration is due to the small film of Isocyanate that lies on the pump shaft during the pumping operation. If the gaskets and the seals are in a good condition, the plasticizer will not have to be changed so frequently.

To replace the plasticizer, proceed as follows:

- a) Spray with the gun until the Isocyanate proportioning pump is placed at the front. Press the ISO PUMP key to interrupt the working cycle. The push-button led will go out.
- b) Press the POWER CONTROL key and turn the general switch OFF. Disconnect the machine from the power supply.
- c) Remove the tank from the support, unscrew the lid, remove the non-return valve of the suction hose, empty the contaminated plasticizer in a suitable vessel and fix the non-return valve in the suction hose again.
- d) Clean the tank, fill it with DOTP, screw on the lid and refit the tank in the support. The system is auto-suction and does not need previous priming.



## CONTENT

<b>Warranty</b>	<b>2</b>
<b>Safety and Handling</b>	<b>3</b>
<b>Characteristics</b>	<b>6</b>
Principal Heating System	6
Hose Heating System	6
Double Acting Piston Proportioning Pumps	6
Recirculation System	7
Central Processing Unit (CPU)	7
<b>Technical Specifications</b>	<b>8</b>
Electrical	8
Mechanical	8
Acoustic	8
<b>General Description Main Components</b>	<b>9</b>
<b>Control Panel</b>	<b>12</b>
<b>Control Screens</b>	<b>17</b>
<b>Alarms</b>	<b>30</b>
<b>Method of Threaded Union of the Hoses</b>	<b>32</b>
<b>Installation</b>	<b>33</b>
<b>Start - UP Procedures</b>	<b>39</b>
<b>Shutdown proCedure</b>	<b>41</b>
<b>Cleaning PROCEDURE</b>	<b>42</b>
<b>Long Term Shutdown Procedures</b>	<b>43</b>
<b>Troubleshooting</b>	<b>44</b>
Heaters	45
Hose Heating	48
Proportioning Pumps	50
Hydraulic Unit	53
<b>Maintenance</b>	<b>54</b>
Heaters	55
Hydraulic Unit	56
Proportioning Pumps	57
Seals assembly	58
Product Inlet Filters	60
Isocyanate Pump Lubrication System	61



Content .....	62
List of Figures .....	63
List of Tables .....	63

## LIST OF FIGURES

Figure 1. Method of union of the Hoses .....	35
--	----

## LIST OF TABLES

Table 1. Tightening Threaded Joints .....	32
Table 2. Elements Values List .....	46
Table 3. Tools for shaft seal assembly .....	58