



# Service Manual

## Proportioning Unit

### evolution G-35 H

Issue 2.0 20/01/22  
Ref. NR-00103-ENG

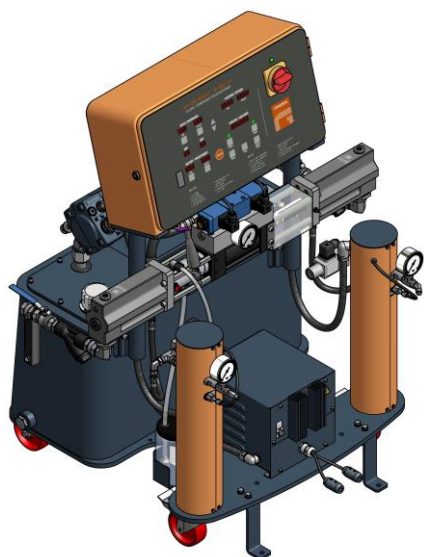

***Before installing the unit and starting it up, carefully read all the technical and safety documentation included in this manual. Pay special attention to the information to know and understand the operation and the conditions of use of the unit. All of the information is aimed at enhancing User Safety and avoiding possible breakdowns derived from the incorrect use of the unit.***



## WARRANTY

HI-TECH SPRAY EQUIPMENT, S. A. (hereinafter "HI-TECH") grants this Limited Guarantee to the original buyer (hereinafter the "Client") for the unit and the original accessories given with the unit (hereinafter the "Product") against any fault in the design, materials or manufacture of the Product at the time of the first purchase by the user and for a duration of two (2) years thereafter.

If during the guarantee period and under normal conditions of use, the Product should fail to work correctly due to defects of design, material or manufacture, the authorised distributor of the country where the HI-TECH Product or technical assistance service has been purchased shall repair or replace the Product in accordance with what is established in the following:

### CONDITIONS

- a) The validity of this guarantee will be subject to the presentation of the original invoice issued by the HI-TECH authorised distributor for the sale of the Product along with the Product handed over for repair or replacement, which must show the date of purchase and the serial number. HI-TECH reserves the right to refuse to give the guarantee service when the indicated data fail to appear on the invoice or have been modified after the purchase of the Product.
- b) The repaired or replaced Product will continue to maintain the original guarantee for the time remaining until the end of the guarantee or for three (3) months from the repair date, if the remaining period of the original guarantee were shorter.
- c) This guarantee will not be applied to the faults in the Product caused by its faulty installation, the natural wear and tear of the components, any use other than that considered normal for this Product or which should fail to strictly comply with the instructions of use provided by HI-TECH; due to accident, carelessness, adjustments, alterations or modifications of the Product not authorised by HI-TECH or due to the use of accessories, heating devices, pumping equipment and/or dispensers that have not been approved or manufactured by HI-TECH.
- d) The guarantee applicable to the components and accessories forming part of the Product and which have not been made by HI-TECH will be limited to the guarantee offered by the original manufacturer thereof.

**HI-TECH WILL NOT RECOGNISE ANY EXPRESS ORAL OR WRITTEN GUARANTEES OTHER THAN THIS PRINTED LIMITED GUARANTEE. ALL IMPLICIT GUARANTEES, INCLUDING, WITHOUT LIMIT, ADAPTATION FOR A SPECIFIC USE, ARE SUBJECT TO THE DURATION OF THIS WRITTEN GUARANTEE. HI-TECH DOES NOT ASSUME ANY KIND OF COMMITMENT OR RESPONSIBILITY FOR ALL POSSIBLE DAMAGE OR EXPENSE CAUSED BY FAULTS IN THE OUTPUT OF THE PRODUCT, ITS WORKING OR THE DISPENSING OF MATERIAL THROUGH THE PRODUCT, INCLUDING, WITHOUT LIMITATION, ALL EXPENSES CAUSED BY DAMAGE TO PEOPLE OR PROPERTY. EQUALLY, HI-TECH WILL IN NO CASE ACCEPT LIABILITY FOR THE LOSS OF SPECULATIVE PROFITS OR COMMERCIAL LOSSES. ALL REPAIRS OR REPLACEMENT OF FAULTY PRODUCTS WILL CONSTITUTE THE COMPREHENSIVE FULFILMENT OF HI-TECH'S OBLIGATIONS WITH RESPECT TO THE CLIENT. HI-TECH DOES NOT IN ANY WAY GUARANTEE THE SUITABILITY OR APTITUDE OF ITS PRODUCT FOR ANY PARTICULAR PURPOSE OR APPLICATION.**

All information provided on components which have not been manufactured by HI-TECH and which is based on reports received from the original manufacturer, though considered precise and reliable, is provided without any guarantee or responsibility of any explicit or implicit kind.

All concession, sale or financial leasing of the Product by HI-TECH in no case explicitly or implicitly constitutes any authorisation, acceptance or concession for the use of any rights or patents, nor does it encourage, nurture or back their infringement.

The restrictions on the guarantee suppose no limitation on the legal rights of the consumer established in applicable national legislation, nor do they affect any rights derived from the bargain and sale agreement between the consumer and supplier.

All information provided in this manual has been included in the confidence that it is true, although it does not constitute any responsibility or implicit or explicit guarantee. HI-TECH reserves the right at any time and without prior warning to make all improvements and modifications necessary to this manual, in order to rectify any possible typographical errors, increase the information contained or insert the changes caused to the characteristics and performance of the unit.



## SAFETY AND HANDLING

The equipment described in this manual has been designed and manufactured in compliance with the following European Directives, following as application guide the harmonized standards detailed and in conformity with the relevant UK Statutory Instruments (and their amendments):



**Directive 2006/42/EC on machinery (UK Supply of Machinery (Safety) Regulations 2008)**

UNE EN 12100:2012 (BS EN ISO 12100:2010)

**Directive 2014/30/EU on electromagnetic compatibility (UK Electromagnetic Compatibility Regulations 2016) (\*)**

UNE EN 55011 (BS UNE EN 55011)

UNE EN 55016-2-1 (BS UNE EN 55016-2-1); UNE EN 55016-2-3 (BS UNE EN 55016-2-3);  
UNE EN 55032 (BS UNE EN 55032)

UNE EN 61000-3-2 (BS UNE EN 61000-3-2); UNE EN 61000-3-3 (BS UNE EN 61000-3-3);  
UNE EN 61000-4-2 (BS UNE EN 61000-4-2); UNE EN 61000-4-3 (BS UNE EN 61000-4-3);  
UNE EN 61000-4-4 (BS UNE EN 61000-4-4); UNE EN 61000-4-5 (BS UNE EN 61000-4-5);  
UNE EN 6100-4-6 (BS UNE EN 6100-4-6); UNE EN 61000-4-8 (BS UNE EN 61000-4-8); UNE  
EN 61000-4-11 (BS UNE EN 61000-4-11)

*(\*) The Unit may experience a degradation of its immunity in the presence of radiated electromagnetic disturbances (IEC 61000-4-3) in the frequency range between 80MHz and 700MHz under an electric field level of 10 V / m, resulting in a temporary loss of function, self-recoverable, according to performance criterion C of the Standard.*

**Directive 2014/68/EU on pressure equipment (UK Pressure Equipment (Safety) Regulations 2016)**

UNE EN 809:1999 +A1 (BS EN 809:1998 +A1:2009)

**Directive 2014/35/EU on electrical safety (UK Electrical Equipment (Safety) Regulations 2016)**

UNE EN 60204-1:2019 (BS EN 60204-1:2018)

**Directive 2003/10/EC on noise level (UK The Control of Noise at Work Regulations 2005)**

UNE EN ISO 3740 (BS EN ISO 3740:2019)

UNE EN ISO 3746 (BS EN ISO 3746:2010)

**Directive 2011/65/EU on the restriction of the use of certain hazardous substances in electrical and electronic equipment with amendment 2015/863/EU (UK The Restriction of the Use of Certain Hazardous Substances in Electrical and Electronic Equipment Regulations 2012)**

**Directive 2012/19/EU on waste electrical and electronic equipment (UK The Waste Electrical and Electronic Equipment Regulations 2013)**

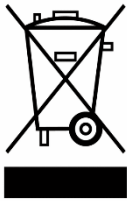

Electrical products cannot be thrown out with the rubbish. They must be taken to a dedicated collection point for an environmentally sound disposal in accordance with local regulations. You must contact your local collective or retailer for information about recycling. Before leaving WEEE at appropriate collection facilities, batteries must be removed and disposed of separately for proper recycling. The packaging materials are recyclable. Dispose of packaging materials in an environmentally sound manner and place them at the disposal of recycling sectors.

### TRANSPORT AND STORAGE

Proper precautions must be taken so that the equipment can withstand the effects of transport and storage temperatures between  $-25^{\circ}\text{C}$  and  $+55^{\circ}\text{C}$  or up to  $+70^{\circ}\text{C}$  for short periods that do not exceed 24 hours. Also, appropriate means to prevent damage from moisture, vibrations or shocks must be foreseen.

This chapter contains information on the safety, handling and use of the **evolution G-35 H** series metering unit.



**Before installing the unit and starting it up, carefully read all the technical and safety documentation included in this manual. Pay special attention to the information to know and understand the operation and the conditions of use of the unit. All of the information is aimed at enhancing User Safety and avoiding possible breakdowns derived from the incorrect use of the unit.**

**WARNING!** establishes information to alert on a situation that might cause serious injuries if the instructions are not followed.

**PRECAUTION!** establishes information that indicates how to avoid damage to the unit or how to avoid a situation that could cause minor injuries.

**NB:** is relevant information on a procedure being carried out.

Careful study of this manual will enable the operator to know the characteristics of the unit and the operating procedures. By following the instructions and recommendations contained herein, you will reduce the potential risk of accidents in the installation, use or maintenance of the unit; you will provide a better opportunity for incident-free operation for a longer time, greater output and the possibility of detecting and resolving problems fast and simply.

Keep this Service Manual for future consultation of useful information at all times. If you lose this manual, ask for a new copy from your **HI-TECH** local distributor or directly contact **HI-TECH SPRAY EQUIPMENT, S.A.**

**WARNING!** The design of the evolution G-35 H series metering unit does not allow its use in potentially explosive atmospheres or to exceed the pressure and temperature limits described in the technical specifications of this manual.

When working with the unit, it is recommended that the operator wear suitable clothing and elements of personal protection, including, without limitation, gloves, protective goggles, safety footwear and face masks. Use breathing equipment when working with the machine in enclosed spaces or in areas with insufficient ventilation. The introduction and follow-up of safety measures must not be limited to those described in this manual. Before starting up the machine, a comprehensive analysis must be made of the risks derived from the products to be dispensed, the type of application and the working environment



**To prevent all possible bodily harm caused by incorrect handling of the raw materials and solvents used in the process, carefully read the safety information provided by your supplier.**

**Deal with the waste caused according to current regulations.**



**Disconnect the unit from the power supply before carrying out any operation inside the electrical console.**

**The electrical maintenance of the machine must only be performed by a qualified electrician.**



**To avoid damage caused by the impact of pressurized fluids, do not open any connection or perform maintenance work on components subject to pressure until the pressure has been completely eliminated.**



**Use suitable protection when operating, maintaining or remaining in the operating area of the unit. This includes, but is not limited to, the use of masks, protective goggles, gloves, shoes and safety clothing.**

**The unit includes components that reach temperatures that are liable to cause burns. The hot parts of the unit must not be handled until they have cooled.**



**To prevent serious harm by crushing or loss of limbs, do not work with the unit without the safety guards installed on all moving parts. Make sure that all of the safety protections are correctly reinstalled after all repair or maintenance work is completed.**

## CHARACTERISTICS

The **evolution G-35 H** metering unit has been designed and built for the application of Polyureas, chemical systems for polyurethane foaming and some two-component epoxy systems.

### Principal Heating System

Consists of two independent heaters without seals. Each heater has four 1500 W heating elements, that give the unit a total power of 6000 W, and the necessary control and safety components for precise operation of the system. Its singular configuration allows a temperature differential ( $\Delta T$ ) of 90° F and application temperatures of up to 194° F under normal conditions of ambient temperature.

### Hose Heating System

Designed with a 3000 W isolation transformer that enables effective heating up to a total hose length of 305 ft for foam and 256 ft for polyurea. The system includes an innovative hose heating concept in which the copper heating element is spread evenly around the circumference of the hose, providing a uniform heating watt density and precise control of the product application temperature. This hose heating element design is extremely resistant to fatigue failure.



100% circumferential coverage produces the most homogenous distribution of heat available.

### Double Acting Opposed Piston Metering Pumps

A pump line driven by a double rod hydraulic cylinder. The in line pump system with opposed piston pumps provides a constant volume and guarantees uniform pressures in both directions of pump movement. Different sized pumps allow for various volumetric ratios to be achieved (1:4 to 4:1) between the chemical components used in the process.

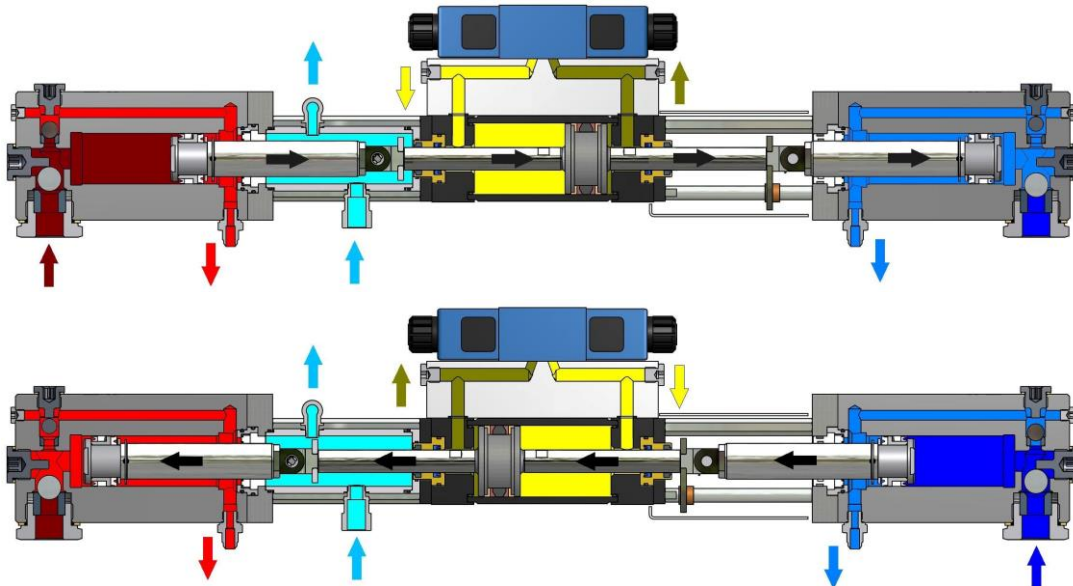



## GENERAL DESCRIPTION

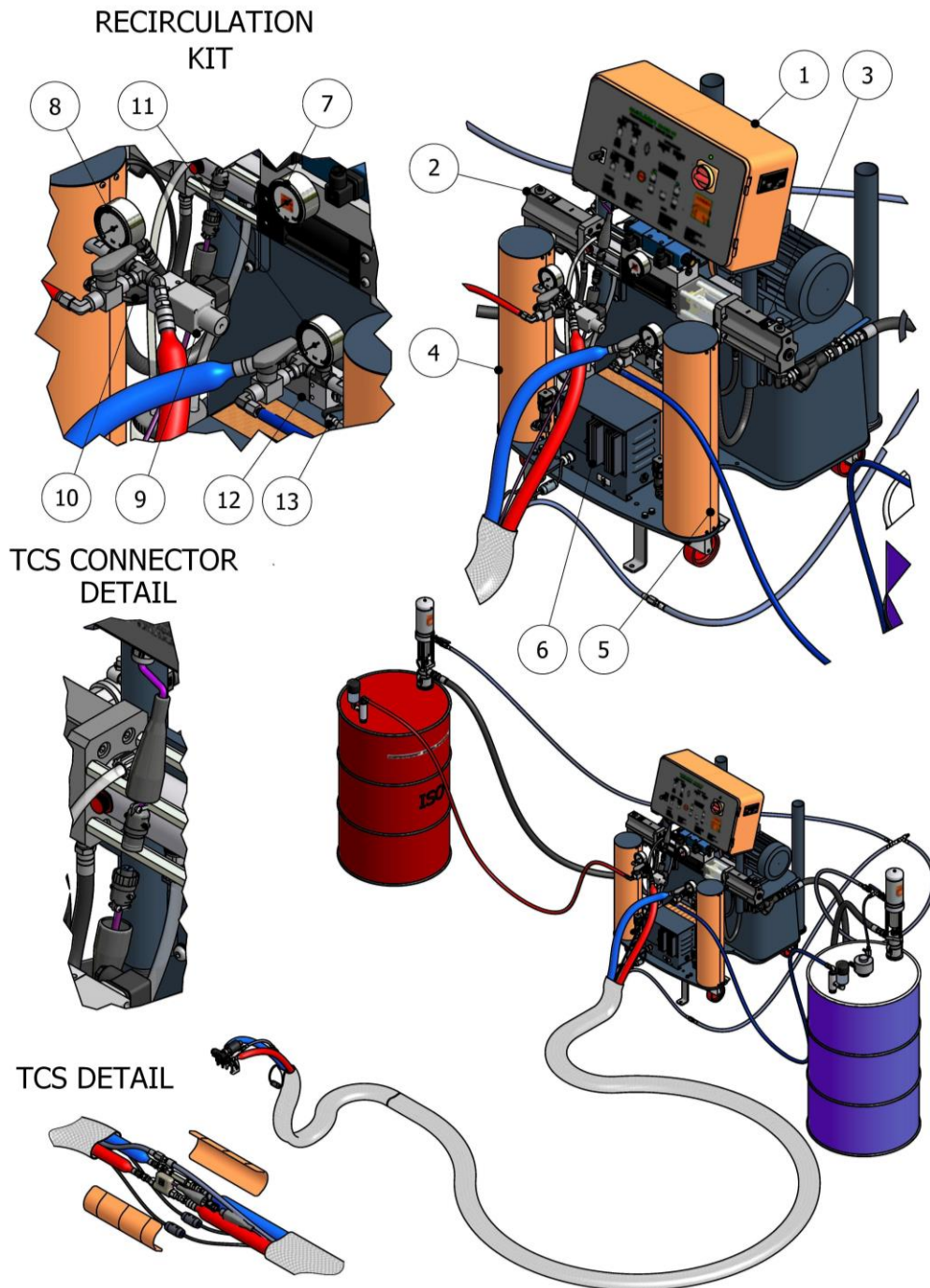

Figure 1. General Description.





## Service Manual

### 1. Control Panel

Controls and regulates the operation of the unit.

### 2. Isocyanate Metering Pump

Meters the Isocyanate.

### 3. Polyol Metering Pump

Meters the Polyol.

### 4. Isocyanate Pre Heater

Heats the Isocyanate to the pre-set temperature.

### 5. Polyol Pre Heater

Heats the Polyol to the pre-set temperature.

### 6. Hose Heating Transformer

Supplies the required voltage for heating the hoses.

### 7. Hydraulic Pressure Gage

Indicates the pressure in the hydraulic drive system.

### 8. Isocyanate Pressure Gage

Indicates the pressure in the Isocyanate system.

### 9. Isocyanate Safety Pressure Switch

Deactivates the directional valve in the event of excessive pressure in the Isocyanate system.

### 10. Isocyanate Temperature probe

Provides information on the temperature of the Isocyanate.

### 11. Polyol Pressure Gage

Indicates the pressure in the Polyol system.

### 12. Polyol Safety Pressure Switch

Deactivates the directional valve in the event of excessive pressure in the Polyol system.

### 13. Polyol Temperature Probe

Provides information on the temperature of the Polyol.

### 14. Recirculation Kit

### 15. Hydraulic Pressure Regulator

Allows the pressure of the hydraulic system to be increased or decreased. Turn the handle clockwise to increase the pressure and counterclockwise to reduce it. In order to regulate the pressure of the hydraulic system, the NORMAL or RETRACT key must be activated.

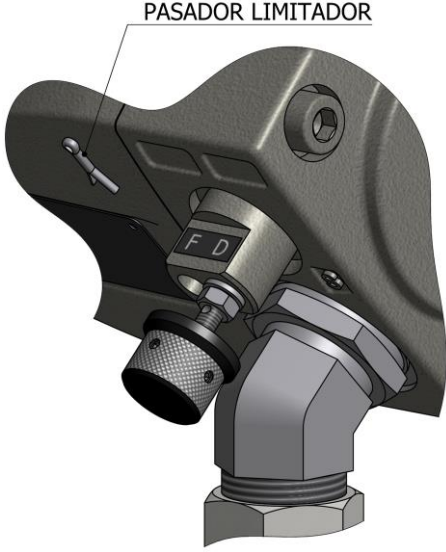
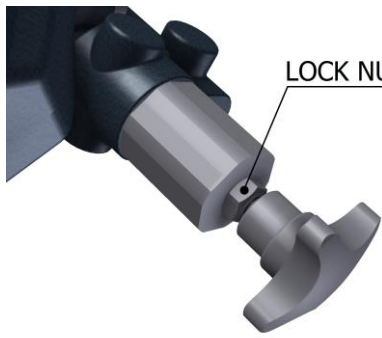
HIDRAULYC PUMP CONFIGURATIONS		
	FOR 18CC PUMPS BOSCH-REXROTH	FOR 20CC PUMPS VICKERS
	 <p>PASADOR LIMITADOR</p>	 <p>LOCK NUT</p>
UP TO 155 bar	Limiting of pressure with pin, for low pressure hoses.	Limiting of pressure with nut, for low pressure hoses.
UP TO 276 bar	Limiting of pressure without pin, for high pressure hoses.	Limiting of pressure without nut, for high pressure hoses.



**Regulate the hydraulic system so that the output pressure of the unit never exceeds the pressure of work of the installed product hoses.**

Service Manual

**16. DIP S1 Selector TPC Probes**

This sets the hose heating control mode to be selected, depending on whether the system includes a single Temperature Control Sensor (TCS) for automatic temperature control or no TCS for manual temperature control.

***Please be aware that after manipulating the DIP selector you should switch off the unit so the change. (in detected buy the board).***

**17. DIP S2 Selector Control Units**

This sets the pressure and temperature units that will be shown on the control panel displays to Metric or English. Set to EU for the pressure to be shown in **bar** and the temperature to be shown in degrees Celsius. Set to USA for the pressure to be shown in **psi** and the temperature to be shown in degrees Fahrenheit. ***Please be aware that after manipulating the DIP selector you should switch off the unit so the change. (in detected buy the board).***



**18. DIP S3 selector – Input Voltage selector**

It allows selecting the input voltage. Moving the 1 switch to ON for 230V with neutral and to OFF for 400V without neutral. Selection is factory set and cannot be modified without HI-TECH technical service authorization. ***Please be aware that after manipulating the DIP selector you should switch off the unit so the change (in detected buy the board).***

## CONTROL PANEL

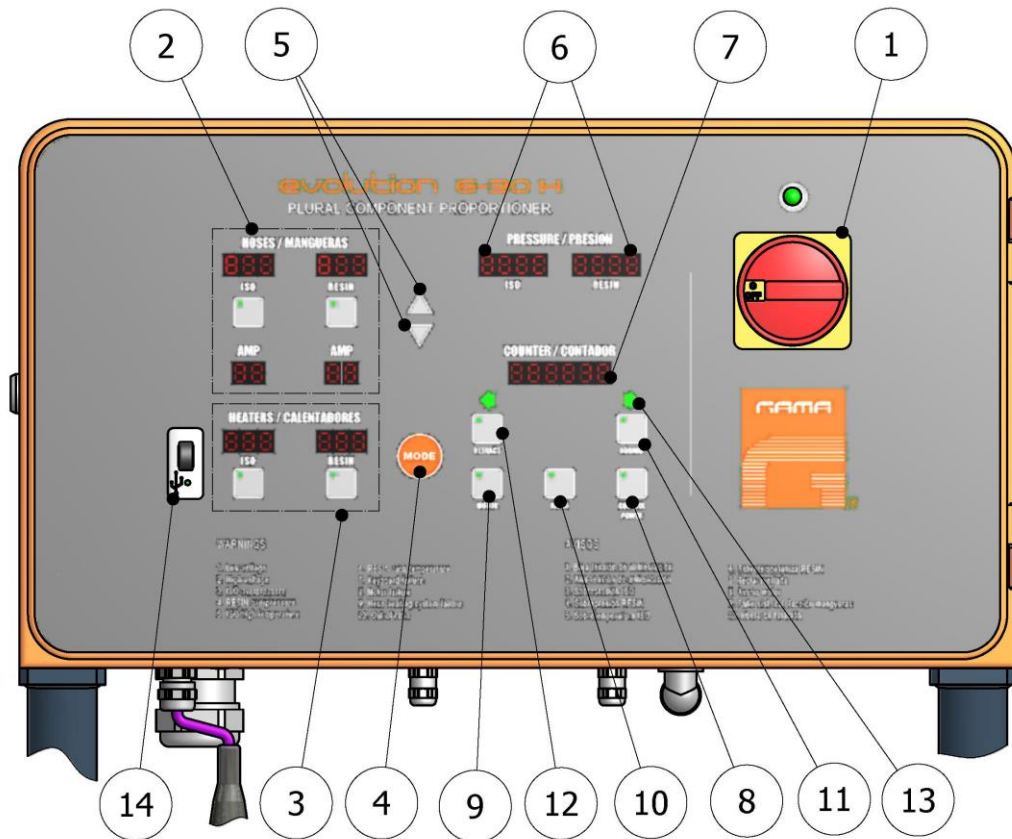

**Figure 2. Control Panel**

The Control Panel allows the optimum working conditions to be selected and set, depending on the characteristics and requirements of the products to be dispensed. Using the MODE key, the different control parameters may be entered. The parameter display will flash for a few seconds to allow the change of this value by pressing the UP / DOWN keys. Once the change is made, press the MODE key once more for the new value to be entered into memory and to select the next parameter for setting.

The modification mode will be interrupted automatically after 3 seconds without activity on the keyboard.

The parameters that may be selected and displayed are the following:

- Hose temperature in automatic control mode (maximum 80° C / 176 F)
- Hose heating power (maximum 50 Amps)
- Isocyanate heater temperature (maximum 90°C / 194 F)
- Polyol heater temperature (maximum 90°C / 194 F)
- Total number of cycles to be made
- Number of cycles made



Service Manual

1. Main Power Switch

Turns the electric supply to the control panel on and off. It must be turned ON for any operation to be performed with the unit. When turned ON, the green pilot at the top of the switch will come on.

2. Hoses

The display shows the temperature of the Isocyanate hose (ISO) and the temperature of the Polyol hose (RESIN).



The hose heating control may be automatic (optional) if using a Temperature Control Sensor (TCS) or manual. The control mode must be established with the two DIP selectors on the printed circuit board (S1).

If the TCS is located in the ISO hose (the recommended placement), then set the Isocyanate DIP selector to ON and the Polyol DIP selector to OFF. In this setup, the Isocyanate temperature will show on the indicator and the Polyol indicator will be blank. If the hose heat system does not include a TCS or the sensor is inoperative, then set both DIP selectors to OFF. In this setup, both temperature indicators will be blank. In the units equipped with two hose transformer power, locate the DIP "Hose ISO" and the DIP "Hose RESIN" to ON position if the hoses have TCS for the temperature control system, or OFF position if the hoses not have TCS.

**Please be aware that after manipulating the DIP selector you should switch off the unit so the change. (in detected buy the board).**

<p><b>ISO on / RESIN off w/TCS</b></p>	<p><b>ISO off / RESIN off manual control</b></p>	<p><b>Dual Hose Heat (optional)</b></p>
--	--	---

To select the temperature when the unit is working in automatic control mode, press the MODE key until the temperature flashes, select the required temperature by pressing the UP/DOWN keys and press the MODE key once more to enter the selected value into memory. Repeat the process to select the Amps. When the unit is in automatic mode, the value of the power must be set between 45 and 50 Amps.

Hose temperature settings that are higher than the temperature settings of the heaters cannot be programmed.

If only one temperature control system is working (ISO or POL), the limiting temperature value will be the highest set in the heaters.

If both temperature control systems are working (ISO and POL), the limiting value will be related to each of their corresponding heaters.

Temperature settings are restricted to 80°C maximum for hoses and 90°C maximum for heaters.



For the data input, the order will be as follows:

- Temperature set-point for A(ISO) heater and B or R (POL).
- Temperature set-point for A(ISO) hose and B or R (POL).
- Amps set-point for A (ISO) and B or R (POL).
- Ratio adjustment.
- Cycles pre-selection.
- Date input

If the TCS stops working, the temperature display will show the symbol (---) and the heating will be automatically turned off.

At start-up, the hose heat set point is not maintained in memory and must be reset after each activation of the CONTROL POWER key.

To select the hose power when the unit is working in manual heating control mode, press the MODE key until the amperage flashes, press the UP / DOWN keys to enter the number of amps required and press the MODE key once more to enter the value into memory.

Refer to the table shown below to select the power that is required to reach the application temperature:

30 A	38° C	100° F
35 A	48° C	118° F
40 A	60° C	140° F
45 A	75° C	167° F
50 A	80° C	176° F

Select the required amps for a quick pre-heating.

**N.B.:**

*The circuit breaker software of the transformer has a safety system to prevent the hoses from being exposed to high temperatures during long periods of time.*

*If you have selected a potential over 35 amperes, after 20 minutes, the potential will automatically regulate to 35 amperes.*

*This potential cannot be set above 35 amperes until the heater is disconnected from the hoses and reconnected.*

*The settings programmed by the machine operator will be stored for the next time the heating is switched on.*



## Service Manual

### 3. Heaters

The display shows the temperature in the Isocyanate heater (ISO) and the temperature in the Polyol heater (RESIN). To enter new temperature values, press the MODE key until the respective temperature flashes; select the required temperature by pressing the UP/DOWN keys and press the MODE key to enter the value into memory.

The pushbuttons turn on or off the heater of each product. Each pushbutton has a led that lights steady when the heater is on; if the led flashes, it indicates that the heater is at the preset temperature.

If the temperature control probe stops working, the temperature display will show the symbol (---) and the heater will automatically be turned off.

At start-up, the heater set point is not maintained in memory and must be reset after each activation of the CONTROL POWER key.

### 4. Mode Key

Allows access to change the different control parameters.

### 5. Up / Down Keys

Allows the value of each of the parameters to be increased or decreased.

### 6. Pressure

Indicator displays the Isocyanate pressure (ISO) and the Polyol (RESIN)

Using the DIP S2 selector labeled USA and EU, the units of pressure and temperature can be set. Set the switch 1 of DIP S2 selector to EU (ON) for the pressure to be displayed in **bar** and the temperature in degrees Celsius; set the switch 1 of DIP S2 selector to USA (OFF) for the pressure to be displayed in **psi** and the temperature in degrees Fahrenheit. ***Please be aware that after manipulating the DIP selector you should switch off the unit so the change. (in detected buy the board).***



### 7. Counter

Indicator displays the cycles used and the cycles remaining from the preset. The cycle counter is incremental and may be reset by simultaneously pressing the UP / DOWN keys.

The system allows pre-selecting the required number of working cycles so that the unit will automatically stop when it reaches this number. To enter the number of cycles to reach automatic shutdown, press the MODE key until the cycle meter flashes, select the number of cycles with the UP / DOWN keys and press the MODE key to enter the value into memory.

When the unit starts, the cycles used will be deducted from the pre-selected cycles until the total number of cycles requested is completed. Once completed, the display will show zero and the unit will automatically stop.

The cycle meter display will alternate every two or three seconds to show the cycles used (totalizer) and the cycles remaining (pre-set). The cycles remaining will be shown by the

Minus sign (-XXXXX). The counter display will also show any alarm warnings resulting from faults.

### 8. Power Control Key

Pushbutton turns on and off the control voltage to the electrical circuit of the heaters and hoses. When the key is on, the led in its center will come on. It may be turned off at will by pressing the key once more, or automatically if an alarm is caused due to excessive temperature in the heaters (alarms 6 and 7) or due to excessive current in the heating system of the hoses (alarm 9).



### **9. Motor Key**

Pushbutton turns on and off the hydraulic motor. When the key is active, the led in its centre will come on. This may be turned off at will by pressing the key once more, or automatically in the event of overload in the hydraulic motor (alarm 8).

### **10. Ratio Key**

Controls that the pressure difference between the two components will not be higher than the programmed (between a 5 and a 25%), if the difference is greater than, the alarm number 10 will be activated. The system to monitor the pressure differential is activated five seconds after pressing the NORMAL key and allows the differential to be exceeded for two seconds before the alarm is set off. The ratio control parameters are factory set. When the key is active, the led in its center will come on.

### **11. Normal Key**

Activates the normal operation of the machine. When the key is active, the led in its center will come on.

### **12. Retract Key**

Sets the piston rod of the Isocyanate metering pump to the retract position and prevents the crystallization of Isocyanate on the piston rod. Press the RETRACT key every time the unit is stopped by the operator. When the key is active, the led in its center will come on.

### **13. Direction Indicator Pilot Lights**

Indicates the direction of movement of the metering pumps. If excessive pressure is caused in the system, the pilot lights will be turned off and alarms 3 and 4 will be set off. The functions of the NORMAL and RETRACT keys will remain active

### **14. USB Port**

Optional connector to insert device of massive storage for capture of data.

Only installed in Units provided with Logger (optional Units).





## ALARMS

When the unit has faults caused by conditions affecting its correct operation, an audible alarm will sound and a fault number will show on the COUNTER display. The system does not allow an alarm to be reset until the fault causing the alarm has been corrected. After resetting, the MODE key must be pressed.

The procedures recommended to determine the possible causes activating the alarms are indicated in the following:

- 1. Maneuvering Voltage under 170 V**
  - Check the electrical supply connections.
  - Check the transformer thermal limit switch.
- 2. Maneuvering Voltage over 270 V**
  - Check the electrical supply connections.
- 3. Excessive ISO Pressure (deactivates the directional valve and the heating system)**
  - Check the product pressure.
  - Check the number 10 led of the printed circuit: it must be lit.
  - Check the over pressure safety switch.
- 4. Excessive POL Pressure (deactivates the directional valve and the heating system)**
  - Check the product pressure.
  - Check the number 11 led of the printed circuit: it must be lit.
  - Check the over pressure safety switch.
- 5. Excessive ISO temperature (deactivates the POWER CONTROL)**
  - Check the heater heating system.
  - Check the connections of the safety thermostat and allow it to cool so that it makes an automatic reset.
  - Check the number 12 led of the printed circuit: it must be lit.
- 6. Excessive POL temperature (deactivates the POWER CONTROL)**
  - Check the heater heating system.
  - Check the connections of the safety thermostat and allow it to cool so that it makes an automatic reset.
  - Check the number 13 led of the printed circuit: it must be lit.
- 7. Fault key (it only turns on when the machine is connected to the mains)**
  - Check the keyboard.
- 8. Motor fault (the motor stops)**
  - Check the amperage draw on the hydraulic motor.
  - Check the electrical connection of the hydraulic motor.
  - Check the number 15 led of the printed circuit: it must be turned off.
- 9. Fault in Hose Heating System (deactivates the POWER CONTROL)**
  - Replace the faulty triac.



**10. Fault Ratio Off Tolerance (deactivates the directional valve)**

- Check the product pressures.
- Replace the pressure transducer if there is no reading.
- Press the ratio key to cancel the function.

**000000 Cycle Pre-selection made (deactivates the directional valve)**

- Press the MODE key to reset the counter
- Set the cycle selector to zero.



***Disconnect the unit from the main power supply before working on the inside of the electrical console. The electrical maintenance of the machine must only be performed by a qualified electrician.***

## METHOD OF THREADED UNION OF THE HOSES

Follow the torques for threaded joints listed in **Table 1** according to thread sizes of hose fittings to ensure their proper assembly.

There is also an alternative procedure to obtain an equivalent torque without using special tools: joint both ends of the hoses to be connected, tighten a swivel nut by hand (without using spanner) until there is resistance on the nut. Fit two spanners (1) on the fixed ends of the hoses and turn the swivel nut with a third spanner (2) as many flats from wrench resistance (FFWR) as indicated in **Table 1**.

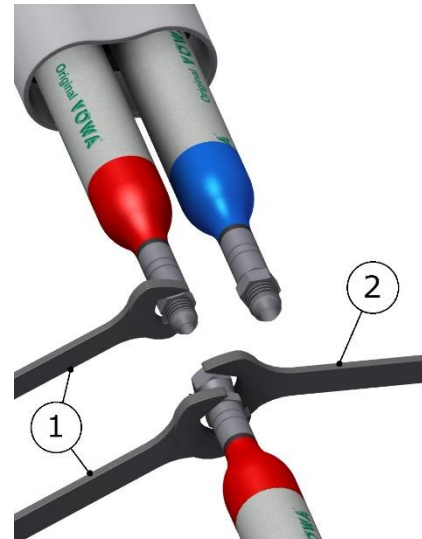

THREAD SIZE	TORQUE Nm	FFWR
1/2"-20	23	2 (or 120°)
9/16"-18	30	1-1/2 (or 90°)

**NOTE:** 1 FFWR corresponds to one complete shear of a flat marked with red between swivel and fitting or else 60°.

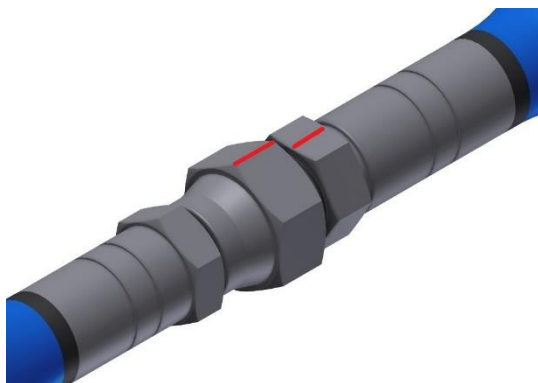



## INSTALLATION

**PRECAUTION!** Use suitable protection and follow the recommendations in the safety information provided by product suppliers when installing or working with the unit.

**HI-TECH** provides a series of tools and accessories necessary for assembling the machine. The kit is made up of the following elements:

REFERENCE	DESCRIPTION	QTY.
BI-00009	Tube of grease Lubriplate 1.75 oz./ 49 gr	1x
NR-00102	Parts Identification Manual	1x
NR-00103	Service Manual	1x
NR-00065	Monobloc Pumps Parts Manual	1x
HT-00001	Magnet holder tools	1x
HT-00003	Pin extractor	1x
MA-00102	12" Hoses Connection Cover	2x
EL-00051-00	ISO TCS Assy (For units with TCS ①)	1x
EL-00051-03	POL Hose Extension (For units with TCS ①)	1x
EM-00012	Hose TCS packaging	1x ①
EL-00093-01	White Flange 300 x 4.8	3x
HT-00045	Allen key 1/8"	1x
EL-00100-06	Blue Terminal for Cable 16 mm <sup>2</sup> L=12mm	2x ①
TN-00242	Threaded Rod 1/4"-20 UNC x 14" nylon	2x ①
OPTIONALS		
EL-00052-00	ISO – POL TCS Assy (For units with 2 Transformers ②)	1x
EM-00012	Hose TCS packaging	1x ②
EL-00100-06	Blue Terminal for Cable 16 mm <sup>2</sup> L=12mm	4x ②
TN-00242	Threaded Rod 1/4"-20 UNC x 14" nylon	4x ②
NR-00093	Recirculation kit Parts Manual	1x

① For Units with 1 transformer & TCS (standard version)

② For Units with 2 transformers & individual TCS each hose of product (optional versions).

Service Manual



**Inside the console there is a terminal strip for connecting the principal electrical wire (not supplied) to the unit. The electrical connection of the unit must only be carried out by a qualified electrician.**

**NB:** To ensure that the unit works correctly, the electrical supply must meet the specifications indicated on page 7 of this manual and appearing on the machine specifications plate.

Follow the recommended procedure in the indicated order to install the unit:

- a) Insert the main power cable by passing it through the wire stop at the bottom of the electrical console and connect as shown in the diagram.

Use the proper size of cable according to the voltage, current and maximum power required by the Unit.

**The sizing of the cable is calculated for a length of 25m, for longer lengths you must recalculate the appropriate section.**

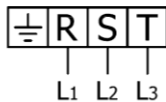

3PE~400V 50/60Hz

38,4 A @ 3PE~400V

Cable Section 6 mm<sup>2</sup>

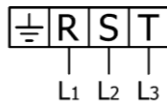

3PE~230V 60Hz

66,6 A @ 3PE~230V

Cable Section 10 mm<sup>2</sup>

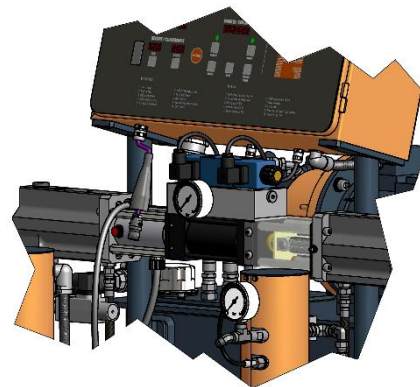

**Make sure the power cable is disconnected from the mains source before connecting it to the terminal strip in the console.**

- b) Load 63 liters (16.6 gal) of hydraulic fluid into the tank of the unit. The oil must be of the characteristics and specifications of DIN 51524 standard, sections 1 and 2 (for example. ISO VG 46).

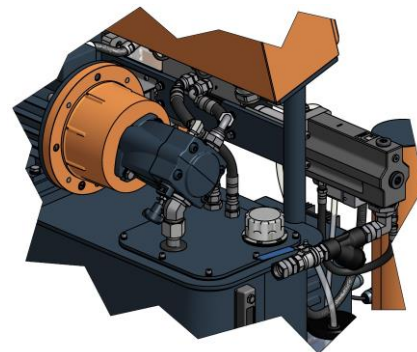

**PRECAUTION!** Do not fill the tank to maximum capacity (78 Lts – 20.6 gal); make sure the amount of oil is not more than 80% of its maximum capacity (63 Lts. – 16.6 gal). Use the visual level indicator of temperature on the tank as a reference, because the maximum temperature limit (80°C – 176°F) coincides with the advised capacity.

- c) Check the level of the oil in the case of the hydraulic pump: remove the plug from the top of the pump case and check that the oil level reaches to the top of the case. Add oil if necessary and refit the plug.
- d) Fill the lube reservoir of the Isocyanate pump with DOTP. It is not necessary to prime the system.
- e) Connect the hoses of the products to the outlets of the respective heaters (the Isocyanate hose to the Isocyanate heater and the Polyol hose to the Polyol heater).



**NB:** The product hoses have been identified with red (Isocyanate) and blue (Polyol), enabling them to be rapidly distinguished. To avoid errors in connecting the coupling connectors of the Isocyanate and Polyol hoses, the connectors are of different sizes to make it impossible for connections to be swapped.

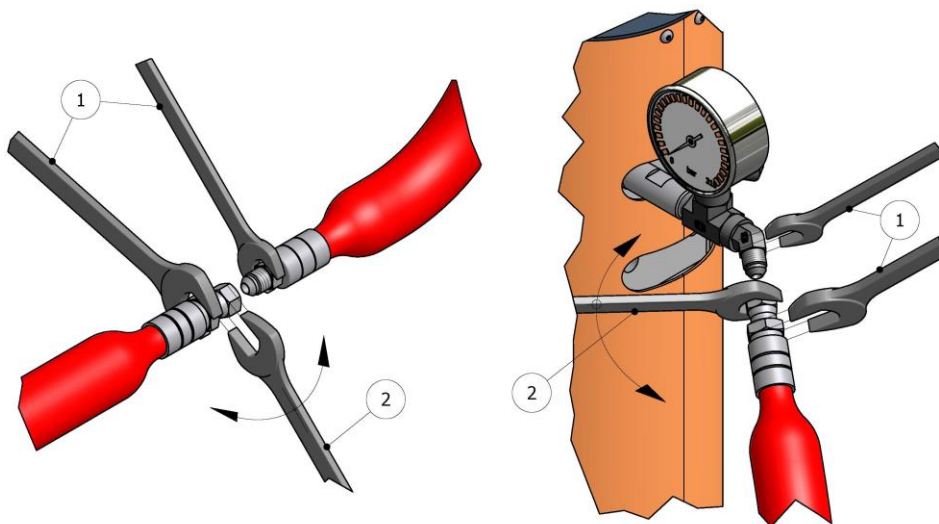

Figure 3. Method of union of the Hoses

**WARNING!** To join the hoses together or to connect them to the heaters or the gun, use two spanners to hold the parts to be joined (1) and a third spanner to tighten or loosen the connecting nut (2) as shown in the illustrations in Figure 3. The connections must be tightened to a torque indicated in Table 1 of pg.19.

Service Manual

The hoses receive vacuum drying treatment and are supplied interconnected at the ends to prevent them from absorbing moisture. Do not separate them until they are going to be installed in the unit.

The hose connection system includes special terminals (fast lock) to facilitate the electrical connection to the transformer and between the different sections installed in the unit.

The transformer offers the option of connecting to a 40 V output voltage valid for a total hose length of up to 48 meters (158 ft), or an output voltage of 75 V, for hose lengths exceeding 48 meters (158 ft) to 93 meters (305 ft). Connect to one output voltage or the other depending on the total hose length installed.

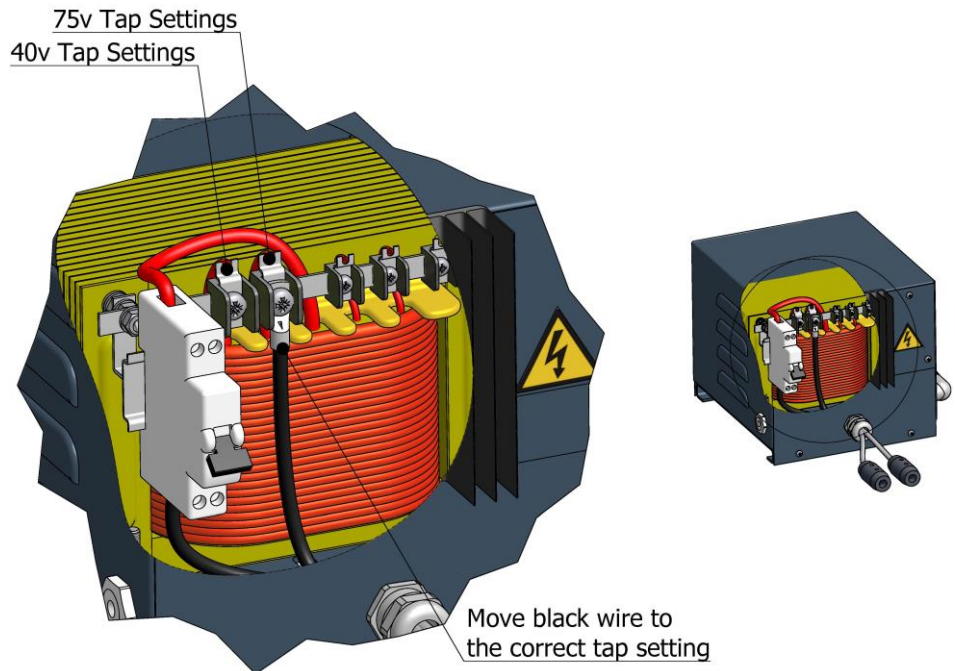

Before starting up the unit, make sure that the connection made in the factory adapts to the total length of hose installed. If you add or eliminate sections of hose, make sure the output voltage of the transformer to which it is connected is suitable for the resulting total length. Otherwise, change the connection.

- f) Connect the heated hoses wires to the “fast lock” connector coming out of the hose transformers as follow:..
  - a. Unscrew the Nylon Safety Plug from the “fast lock” connector body.
  - b. Unscrew partially the Socket Head Set Screw from electrical wires.
  - c. Insert the heated hose electrical wire with terminals into the “fast lock” connector body.
  - d. Tighten the Socket Head Set Screw of the terminals and place the Nylon Safety Plugs

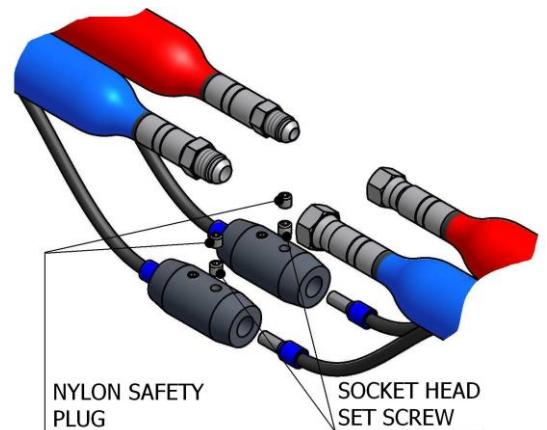

**NB:** A good practice is to add some dielectric grease to the ID of the connector.

Repeat the same steps to connect the “fast lock” that you will find in the middle hose connections

- g) Connect the rest of the product hoses to complete the required length. Remember that the hoses are identified with red (Isocyanate) and blue (Polyol).

**NB:** Assure the proper mechanical and electrical connection of the hoses to avoid possible product leakage and hose heat problems.

- h) Install the probe of control of temperature TCS between the last stretch of hose of product and the final stretch connected to the gun. Stretch carefully the cable of the probe inserting it in the Isocyanate hose.
- i) Wind the connector of the probes to the connector of the hose. Realize so many connections as stretches of 15 m hose you have.
- j) Realize the connections between the connector of exit of the probe TCS of the first stretch of hose and the connector proceeding from the machine
- k) As soon as the connections were completed, place the protections for the union fixing them with three plastic bridles. Later cover the union with the ends of the cases.

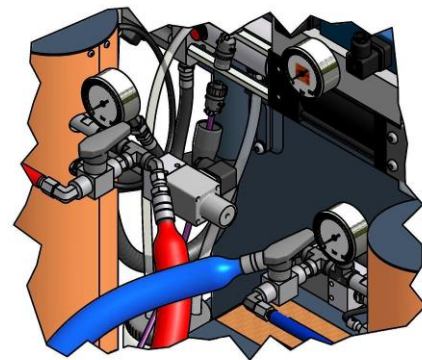
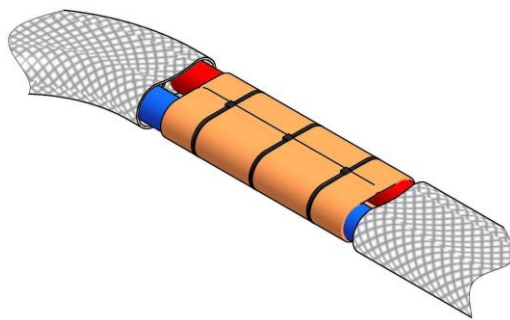
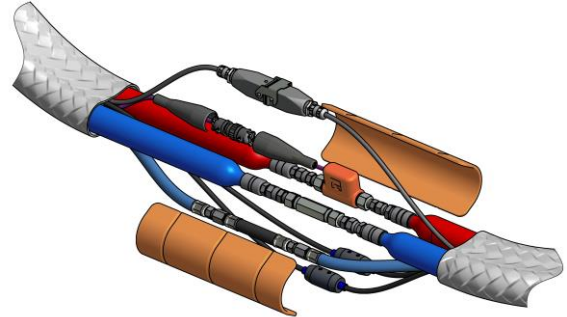

**NB:** To protect the TCS sensor, you must pay special attention not to kink or excessively bend the hoses. Do not roll up the hoses with a radius of under one meter / 4 feet.

- l) Connect the air hoses.
- m) Connect the hoses to the connectors of the coupling block of the gun, making sure that the manual valves are closed.

Having performed the above operations, you must note the direction in which the motor turns. To make sure that it is turning clockwise, do the following:

- a) Turn the hydraulic pressure regulator counter clockwise.
- b) Turn the general switch ON. The top pilot light will come on.
- c) Press the POWER CONTROL key.
- d) Go to the side of the machine to be able to see the motor fan. Press the MOTOR key to start the motor and press it again to stop it. Check that the blades of the fan are turning clockwise, otherwise turn the general switch OFF and disconnect the machine from the source of electrical supply.
- e) Open the console of the control panel and change the position of two of the three wires of the electrical connection of the unit. Check the turning direction once more.





## Service Manual

Proceed to install the transfer pumps paying special attention to connect each pump to “its” respective product, as changing the pumps would cause a reaction in the products inside them and make them useless. Identifying each pump with a tape of the same color as that of the hoses (blue for the Polyol pump and red for the Isocyanate pump) might be a good method for avoiding errors in connection.

Do the following steps to install the pumps:

- a) Make sure that the inlet valves of the products to the unit are closed.
- b) Connect one end of the Polyol hose ( $\frac{3}{4}$ " thread) to the Polyol valve and the other end to the transfer pump of the same product.
- c) Connect one end of the Isocyanate hose ( $\frac{1}{2}$ " thread) to the Isocyanate valve and the other end to the transfer pump of the same product.
- d) Connect the air hose to the transfer pumps.
- e) Install the unit ground connection. The movement of the product inside the hose can cause static electricity and produce electrical discharges.

Before using the unit, the residual air and oil from factory testing must be eliminated. To purge the whole circuit, proceed as follows:

- f) Pressurize the transfer pumps and open the inlet ball valves. Make sure there are no leaks.
- g) Turn the hydraulic pressure regulator counter clockwise.
- h) Turn the general switch ON. The top pilot light will come on.
- i) Press the POWER CONTROL key.
- j) Hold the coupling block with the outlet of each product in separate vessels and open the manual valves of each product.
- k) Press the MOTOR key.
- l) Press the NORMAL key. The led will light
- m) If necessary, increase the hydraulic pressure by turning the regulator clockwise until the product pumps begin to move slowly.
- n) Allow the materials to come out of the coupling block until the residual oil and the air bubbling has disappeared completely.
- o) Close the manual valves of each product and clean the coupling block of the remains of product.
- p) Slowly increase the hydraulic pressure to check for product leaks in the hose joints. Retighten if necessary and tape the connectors to protect them from possible damage.
- q) Press the NORMAL key. The led will go out.
- r) Place the gun in the coupling block.

## START - UP PROCEDURES

Follow the recommended procedure in the indicated order.

**PRECAUTION!** *The start-up procedures assume that all of the necessary adjustments have been correctly performed.*

- a) Check the state of the DOTP plasticizing oil in the lubrication tank of the Isocyanate pump. Change the oil if you see changes in the color or signs of solidification.
- b) Check the hydraulic oil level. Add oil if the level is low.
- c) Make sure that the chemical products to be processed are above the minimum temperature required to be supplied to the unit through the transfer pumps. Ask your product supplier for information on the minimum supply temperature.
- d) Check the input filters of the products. Clean them if necessary.
- e) Pressurize the two transfer pumps and open the inlet valves of the products to the unit.
- f) Turn the general switch ON. The top pilot light will come on.
- g) Press the POWER CONTROL key. The led will light.
- h) Press the ISO key under the HOSES display. The led will light in the center of the key. In machines fitted with two transformers, the ISO and RESIN keys must be pressed. The two leds will light.
- i) Press the ISO and RESIN keys under the HEATERS display when the products in the hoses reach the working temperature. The two leds will light.



**PRECAUTION!** *To avoid excessive pressure in the heating hoses, wait for the product in them to reach the required temperature before starting up the hydraulic system.*

- j) Press the MOTOR key. The led will light.
- k) Press the NORMAL key. The led will light. One of the direction indicator lights will come on and the dosing pumps will begin to move.
- l) Using the hydraulic pressure regulator, adjust the required pressure and check the pressure of each dosing pump on their respective gages on the machine outlet.



**Regulate the hydraulic system so that the output pressure of the unit never exceeds the pressure of work of the installed product hoses.**

The pressures must be practically the same and remain constant. The directional indicator lights must remain with one on and the other out. The lit lamp indicates the direction of movement of the pumps.

If the pressure fluctuates on either stroke, consult the fault section before continuing.

- m) Connect the air supply to the gun; open the manual valves of each product; make a test projection and check the pressures on the product gages. If the projection test is correct and the pressures remain equal, proceed with the application



## SHUTDOWN PROEDURES

Follow the recommended procedure in the indicated order for machine shut down when work is stopped for the day.

- a) Press the RETRACT key. The led will light.
- b) Use the gun to project into a waste container until the Isocyanate metering pump is in the retract position and the pressure begins to fall.

***PRECAUTION!*** To avoid possible seal weep age and the early failure of the pump seals, the pressure must not be reduced to zero. It is recommended to keep the system with a minimum pressure of 30 bar (400 psi) to extend the life of the seals.

- c) Press the MOTOR key. The led will go out.
- d) Press the ISO and RESIN keys under the heater temperature display. The two leds will go out.
- e) Press the ISO key under the HOSES display. The led will go out. In machines fitted with two transformers, the ISO and RESIN keys must be pressed. The two leds will go out.
- f) Press the POWER CONTROL key. The led will go out.
- g) Turn the general switch OFF. The top pilot light will go out.
- h) Close the inlet ball valves.
- i) Close the supply to the transfer pumps.
- j) Disconnect the air supply to the transfer pumps
- k) Close the manual valves of the coupling block and remove the gun to perform the corresponding maintenance.



## CLEANING

***PRECAUTION!*** *The unit includes components that reach temperatures that are liable to cause burns. The hot parts of the unit must not be handled until they have cooled.*

To avoid possible contamination, the circuits of the unit must previously be cleaned (pumps, heaters and hoses) whenever applications have to be made that require a change of components.

Follow the recommended procedure in the order indicated to perform the cleaning when you have to change the components of the system:

- a) Place two drums of DOTP cleaning agent close to the machine.
- b) Dismantle the gun and leave the coupling block connected to the hoses.
- c) Remove the transfer pumps of the product drums and place them in the drums of the DOTP cleaning agent.
- d) Place a vessel under the coupling block to gather up the products contained inside the machine.
- e) Open the manual valves on the coupling block and press the MOTOR and NORMAL keys to start up the metering pumps.
- f) Allow the products to come out until you see that only DOTP cleaning agent comes out free of impurities.
- g) Close the valves on the coupling block and deactivate the MOTOR and NORMAL keys.
- h) Place the transfer pumps in the drums of the new products.
- i) Place a vessel under the coupling block to collect the DOTP cleaning agent.
- j) Open the valves on the coupling block and press the MOTOR and NORMAL keys to start up the dosing pumps.
- k) Allow the DOTP cleaning agent to come out until you see that only the new products come out.
- l) When the products come out without the contamination produced by the effect of the DOTP cleaning agent, the cleaning process is complete and you can proceed as normal.



## LONG TERM SHUTDOWN PROCEDURES

***PRECAUTION!*** *The unit includes components that reach temperature that are liable to cause burns. The hot parts of the unit must not be handled until they have cooled.*

When you plan to shut down the machine for more than FOUR weeks, the products contained in the machine must be replaced by DOTP plasticizing agent.

Follow the recommended process in the order indicated, to change the products for DOTP oil:

- a) Place two drums of DOTP cleaning agent close to the machine.
- b) Dismantle the gun and leave the coupling block connected to the hoses.
- c) Remove the transfer pumps of the product drums and place them in the drums of the DOTP cleaning agent.
- d) Place a vessel under the coupling block to gather up the products contained inside the machine.
- e) Open the manual valves on the coupling block and press the MOTOR and NORMAL keys to start up the dosing pumps.
- f) Allow the products to come out until you see that only DOTP cleaning agent comes out free of impurities.
- g) Deactivate the MOTOR and NORMAL keys, close the valves on the coupling block, turn the general switch OFF, disconnect the supply system of the transfer pumps and the process is finished. The metering pumps, the heaters and the hoses must be full of DOTP plasticizing oil. Never leave the machine or the hoses empty of product or DOTP plasticizing oil.

***NOTE:*** *Never use liquids not recommended or not approved by HI-TECH. Never use approved liquids that have been contaminated with water or ISO/POL. If you are not sure in the quality of the liquid you are going to use we strongly recommend that you check the machine 2-3 times every 2 weeks after you have filled it by recirculating through heated hoses (see p.28) with fresh plasticizer unless you make sure the liquid that comes out is completely pure and clean.*

## TROUBLESHOOTING

The **evolution G-35 H** unit has been designed and built to withstand severe working conditions with a high degree of reliability, provided it is used suitably. This chapter contains information on possible faults that may prevent the continuation of work with the unit. The information provided must serve as guideline to detect and resolve the large majority of the problems before calling for the assistance of the authorized distributor or **HI-TECH** technical service. In any case, feel free to contact the technical assistance service of **HI-TECH SPRAY EQUIPMENT S.A.**, where a qualified technician will advise you on whatever you may need.

**All repairs performed by unqualified personnel or the use of spares other than originals may cause damage to the unit and put the operator at risk.**



**To prevent possible bodily harm caused by incorrect handling of the raw materials and solvents used in the process, carefully read the safety information provided by your supplier.**

**Deal with the waste caused according to current regulations.**



**Disconnect the unit from the power supply before carrying out any operation inside the electrical console.**

**The electrical maintenance of the machine must only be performed by a qualified electrician.**



**To avoid damage caused by the impact of pressurized fluids, do not open any connection or perform maintenance work on components subject to pressure until the pressures have been completely eliminated.**



**Use suitable protection when operating, maintaining or remaining in the operating area of the unit. This includes, but is not limited to, the use of face masks, protective goggles, gloves, shoes and safety clothing.**

**The unit includes components that reach temperature that are liable to cause burns. The hot parts of the unit must not be handled until they have cooled.**



**To prevent serious harm by crushing or loss of limbs, do not work with the unit without the safety duly installed on all moving parts. Make sure that all of the safety protections are correctly fitted after all repair or maintenance work.**

## Heaters

**WARNING!** Before resolving any kind of defect, make sure all of the pushbuttons are off, that the general switch is in shutdown position and that the unit is disconnected from the power supply. Never handle the inside of the control panel with the unit connected to the power supply. The heaters are components that reach high temperatures; wait until they have cooled before handling.

**NB:** The thermostat is a safety element in contact with the heater. If the temperature exceeds 120° C (248° F) the thermostat will cut off the electric supply by deactivating the POWER CONTROL. The thermostat will not reset until the temperature in the heater is below 120° C (248° F).

If the temperature in the Isocyanate heater or the Polyol heater is over 120° C (248° F), an alarm will be activated and the corresponding number will be shown on the control panel (5 for Isocyanate and 6 for Polyol).

Follow the recommended procedure in the order indicated, to try to solve the problem and avoid costly repairs. Make sure all the automatic switches and control elements are in the correct working position before determining the existence of a fault.

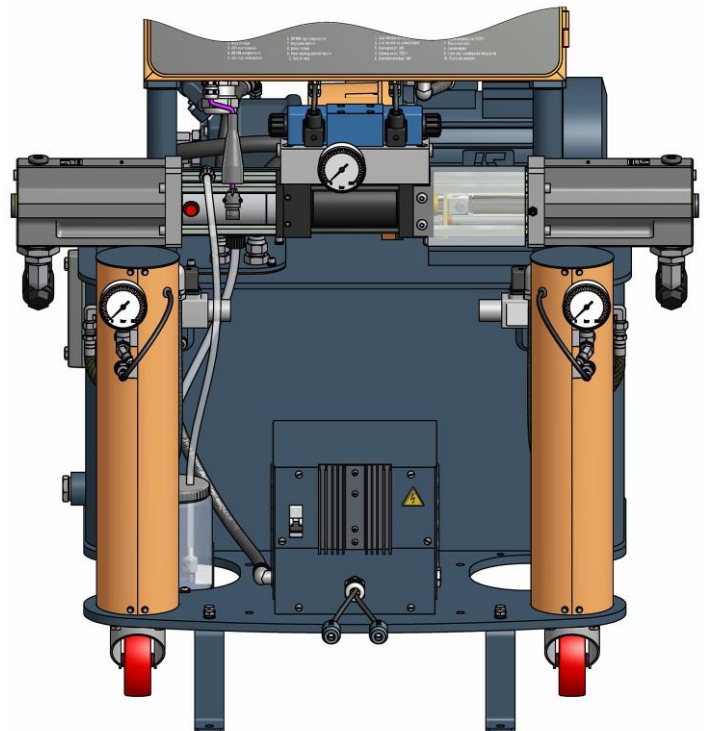

### PROBLEMS

The heater fails to heat, the pushbutton led is lit.

The heater display shows the symbol (---)

### SOLUTIONS

#### 1. Static Relay

This determines that the static relay is not working when all of the previous checks have been correct.

### SOLUTIONS

1-2-3

4

## 2. Heating Resistances

Each heater has four 1500 W elements connected in parallel, which give the system a total power of 6000 W. If under normal conditions of ambient temperature, it is not possible to reach the temperature required in two or three minutes, it is possible that one or several heating elements are not working.

To check the state of the element, proceed as follows:

With the main switch off check with a tester that reading the total value of the heater resistance is indicated in the table according to the power, voltage and number for each installed heater elements, a higher value would indicate that one or more elements are faulty .

Disconnect them and check that the individual value of each element is as shown in the table according to the installed power and voltage.

**Table 2. Elements Values List**

(W)	(V)	x1 (Ω)	x2 (Ω)	x4 (Ω)	x6 (Ω)
450	230	117±2	58±2	29±2	19±2
900	230	58±2	29±2	14±2	9±2
900	400	177±2	88±2	44±2	29±2
1250	230	42±2	21±2	10±2	7±2
1250	400	128±2	64±2	32±2	21±2
1250	440	154±2	77±2	38±2	25±2
1500	230	35±2	17±2	8±2	5±2
1500	400	106±2	53±2	26±2	17±2
1500	440	129±2	64±2	32±2	21±2
1800	230	29±2	14±2	7±2	4±2
1800	400	88±2	44±2	22±2	14±2
1800	440	107±2	53±2	26±2	17±2
2000	230	26±2	13±2	6±2	4±2
2000	400	80±2	40±2	20±2	13±2
2000	440	96±2	48±2	24±2	16±2

Under extreme environmental conditions, the heater might be affected and fail to reach the required temperature. In this case, put the unit in a more favorable place, or use an auxiliary heating system.

## 3. Automatic Switch

This protects the elements against any possible change in voltage. With the general switch turned off, open the control panel and make sure the switch is activated (see electrical diagram), otherwise activate it.





**4. Temperature**

The control panel automatically detects any fault in the operation of the temperature. If the fault occurs, replace the probe, paying special attention not to damage it when assembling. The probe must be in firm physical contact with the element.



## Hose heating

**WARNING!** Before resolving any kind of defect, make sure all of the pushbuttons are off, that the general switch is in shutdown position and that the unit is disconnected from the power supply source. Never handle the inside of the control panel with the unit connected to the power supply. The hoses can reach high temperatures; wait until they have cooled before handling.

If a fault occurs in the heating system of the hoses, an alarm will be activated and the number 9 will be shown on the control panel.

Follow the recommended procedure in the order indicated, to try to solve the problem and avoid costly repairs. Make sure all the automatic switches and control elements are in the correct working position before determining the existence of a fault.

### PROBLEMS

- The hose is hot, but fails to reach the selected temperature.
- The hose is not hot; the pushbutton led is lit.
- Only the sections of the hose closest to the unit are heated.
- The hose display shows the symbol (---).
- The automatic switch is triggered.

### SOLUTIONS

- 1-2-7
- 2-3-4-5
- 5
- 6
- 3

### SOLUTIONS

#### 1. Hose Length

The **evolution G-35 H** has been designed to work with a maximum hose length of 93 meters (310 ft). A longer length will render the heating capacity less effective. Under extreme ambient conditions, the hose heating system may be affected and fail to reach the required temperature.

#### 2. Hose Transformer

The transformer offers the option of connecting to a 40 V output voltage valid for the connection of hose sections with a total length of up to 45 meters (160 ft), or an output voltage of 75 V, for connecting hose lengths of over 45 meters (160 ft); connect to one or the other position depending on the total hose length installed in the machine. If the connection is performed incorrectly, the hoses will not reach the required temperature.

#### 3. Automatic Switch

This protects the secondary circuit of the transformer. The switch is located on the front of the transformer; make sure it is activated, otherwise activate it. Replace it with one of equal amperage if the switch fails to work correctly.

**PRECAUTION!** The replacement of the automatic switch with another of different characteristics may cause damage to the equipment and put the operator at risk.



## Service Manual

### 4. Triac

This determines that the triac is faulty when all of the previous checks have been correct. Replace the triac if it fails to work correctly.

### 5. Hose Heating Components

With the general switch turned off, make sure the hose connections and the electrical connections between the hoses and the unit are correct and tight. If the connections are correct and the hoses do not heat up, check section by section to locate the connection that is at fault.

Proceed as follows:

- a) Disconnect the unit from the power supply by deactivating the general switch and start to check the hose section closest to the gun. Remove the "Fast Lock" connector, and make a "bridge" on the connection immediately before.
- b) Restore the power supply, press the POWER CONTROL key and the ISO and RESIN keys under the HOSES display. If the heating works, the problem will be in the last section of hose. Replace it. If not, do the following.
- c) Disconnect the unit from the power supply, remove the "Fast Lock" connector from the last section of hose and make a "bridge" on the connection immediately before.
- d) Restore the power supply, press the POWER CONTROL key and the ISO and RESIN keys under the HOSES display. If the heating works, the problem will be in the last but one section of hose. Replace it. If not, repeats steps c) and d) until you find the point of the fault.

### 6. TCS Temperature Control

The control panel automatically detects any fault in the operation of the temperature sensor. To determine if the mistake is caused by the proper probe or by a defective electrical connection, realize the following cross-check: dismantling the electrical connector of the probe TCS of the last stretch of hose and without dismantling any other connection connect it straight to the electrical capture of the exit of the machine, if the control is restored check the electrical connections of the probe existing TCS in the intermediate stretches of the hoses, in the opposite case replace the probe TCS.

### 7. Hose Heating Temperature Adjustment

The hose heating system maintains the temperature of the products exiting the heaters, which is why the value set for the temperature of the hoses must be the same as that selected on the heater display.

## Metering pumps

**WARNING!** Before resolving any kind of defect, make sure all of the pushbuttons are off, that the general switch is in shutdown position and that the unit is disconnected from the power supply source. Never handle the inside of the control panel with the unit connected to the power supply. The metering pumps are components that work under pressure; do not open any connection or perform repair or maintenance work on components subject to pressure until all of the pressures have been completely eliminated.

If excessive pressure is caused in the Isocyanate circuit or the Polyol circuit, an alarm will be activated that will be shown on the control panel (3 for the Isocyanate and 4 for the Polyol).

Follow the recommended procedure in the order indicated, to try to solve the problem and avoid costly repairs. Make sure all the automatic switches and control elements are in the correct working position before determining the existence of a fault.

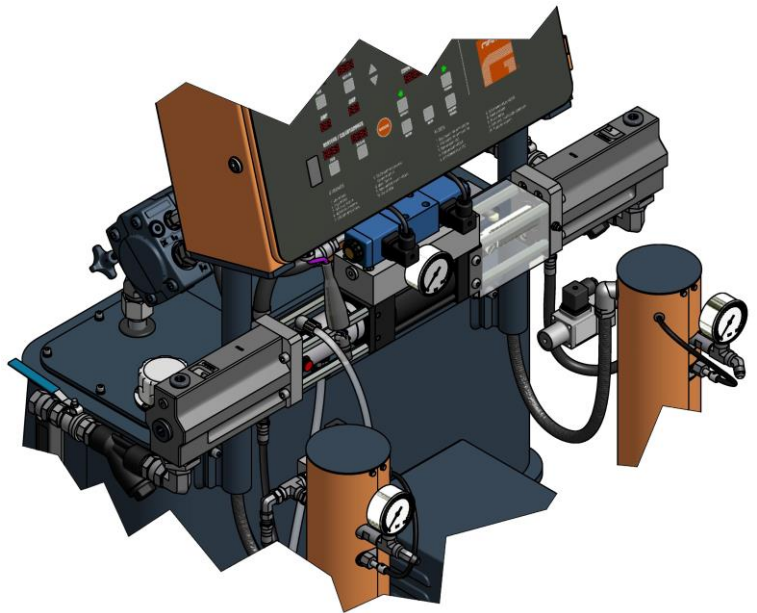

### PROBLEMS

The pumps fail to maintain the pressure when the unit is shut down.

There are pressure differences between the metering pumps.

There is cavitation in the metering pump.

The metering pumps do not change direction.

The metering pumps fail to move and the direction indicator lights are out.

The movement of the metering pumps is erratic.

### SOLUTIONS

1

1-2-3

1-2-3

4

4-5

4

### SOLUTIONS

#### 1. Loss in the Valve Ball

Observe the pressure gages to identify which pump fails to maintain the pressure and check the direction indicator light to determine in which direction the pump fails to maintain the pressure. If the lit lamp is the left hand one and the pressure is lost in the Polyol pump, check the discharge valve ball of the Polyol pump; or check the inlet valve ball of the Isocyanate pump, if the pressure loss is caused in the Isocyanate pump. If the lit lamp is the right hand one and the pressure is lost from the Polyol pump, check the inlet valve ball of the Polyol pump; or check the discharge valve ball of the Isocyanate pump, if the pressure is lost from the Isocyanate pump.



## Service Manual

Proceed as follows to check the valve balls:

- a) Disconnect the machine from the power supply and close both inlet ball valves and the supply system to the transfer pumps.
- b) Depressurise the metering pump and remove the corresponding valve ball.
- c) The loss from the valve ball is usually caused by foreign particles that prevent the perfect coupling of the ball with the ball seat. Clean the ball and the seat and make sure there are no faults from knocks, marks or scratches to the seat or the ball. If cleaning fails to resolve the problem or any fault is observed, replace the seat and the ball.

### 2. Decompensated Pressures

Pressures are decompensated when there is an obstruction in the hose or in the gun that prevents one of the components from leaving freely through the gun chamber when it is projected, or when a problem in the pumping system prevents one of the components reaching the gun in the required amount.

It is relatively easy to identify which component is problematic if we bear in mind that the chemical components used in the polyurethane foaming are of a different color. By observing the color of the material that leaves the gun, we can determine which component is missing.

To determine whether the decompensation is caused as a result of an obstruction or as a consequence of a problem in the pumping system, project with the gun, observe the pressure indicated on the corresponding pressure gage to the missing component and compare it with the pressure indicated by the gage to the other component: if the pressure of the missing component is higher, the decompensation is the result of an obstruction, if the pressure is lower, the decompensation is the consequence of a problem in the pumping system.

### 3. Cavitation

Cavitation occurs when the metering pump requires a larger volume of material than that supplied by the feeding system, causing the formation of a vacuum in the inlet of the metering pump. The causes of cavitation are the following:

- a) The transfer pump fails to supply the necessary volume. The problem might be in the pump not meeting the required specifications, in the lack of air supply to the pump or that the pump is faulty. A pump is recommended with a ratio of 2:1 for transferring the Isocyanate and a supply hose with an interior diameter of at least 20 mm ( $\frac{3}{4}$  in).
- b) High viscosity. The polyurethane foaming systems normally require a minimum transfer temperature of 12° C (55 F); at lower temperatures, the product increases its viscosity, making the pumping more difficult. When the ambient conditions prevent the products from being maintained at a minimum temperature of 12° C (55 F) auxiliary heating elements must be used to condition the products as the minimum temperature required for the transfer.
- c) The product inlet filter is obstructed (see Maintenance).
- d) The inlet valve ball has leaks as a result of wear or possible faults in the ball or the closing surface of the seat, which means that part of the material supplied returns to the supply tank and that the metering pump supplies a smaller volume of material in the discharge cycle, causing an incorrect ratio.

### 4. Fault in the Reversing Switch

The metering pump system has a plate that activates the reversing switches to carry out the change of direction. The most common cause of the fault is the deformation of the plate or the entry of a foreign body preventing the plate from making contact with the micros.

A fault in the movement of the directional valve will cause the activation plate to pass the micro and not make the change of direction. Proceed as follows to solve this problem:



- a) Determine the direction in which the plate must move; this depends on which micro has been passed.
- b) Locate the slide for the manual activation of the directional valve in the hydraulic distributor: this is located on the same side of the machine towards which the activation plate must work.
- c) Turn the general switch ON, press the POWER CONTROL key and the MOTOR key. With the manual valves of the coupling block open, point the gun at a waste container.
- d) Press the manual slide of the directional valve and hold it until the activation plate is centred between the two run end micros.
- e) If when pressing the slide, it moves freely, the excess run is due to an electrical problem. Press the MOTOR key and the NORMAL key; press the run end micros and check whether the reels are changed and the direction indicator lights: if the reels are not changed or the direction indicator lights fail to come on, there is an electrical problem in the run end micro or in the reels of the directional valve.

#### 5. Over Pressure Safety Switch

Each metering pump is protected by a safety pressure switch factory set to limit the pressure depending on the size of the pumps installed in the unit. For **1.2** and **0.8** size pumps, the limit pressure set in the factory is 270 bar (3900 psi). When the limit pressure is reached, the pressure switch interrupts the electrical supply to the directional valve, stopping the pumps. When the pumps stop, the direction indicator lights will go out and an alarm will be activated that will be shown on the control panel (3 if the excess pressure is caused in the Isocyanate circuit or 4 if it is caused in the Polyol circuit).

When the pressure reaches lower values than the established limit, the metering pumps will restart. However, the causes of the excess pressure must be determined and corrected.



## Hydraulic unit

**WARNING!** Before resolving any kind of defect, make sure all of the pushbuttons are off, that the general switch is in shutdown position and that the unit is disconnected from the power supply. Never handle the inside of the control panel with the unit connected to the power supply. The hydraulic unit is a component that works under pressure; do not open any connection or carry out maintenance work on components subject to pressure until all of the pressures have been completely eliminated.

Follow the recommended procedure in the order indicated, to try to solve the problem and avoid costly repairs. Make sure all the automatic switches and control elements are in the correct working position before determining the existence of a fault.

### PROBLEMS

### SOLUTIONS

The electric motor does not start or stops while it is working.	1
The hydraulic pump fails to develop pressure.	2
Little or no pressure with screeching.	2-3

### SOLUTIONS

#### 1. Automatic Switch

The electric motor is protected by an overload safety switch that triggers when the motor draws excessive current. Disconnect the machine from the power supply, allow the motor to cool, open the control panel and reset the automatic switch for the motor. It is important to determine the reason why the motor has been subject to an overload. Reset one time only or the electric motor may be damaged due to overheating.

#### 2. Little or No Pressure

The most likely causes of low or no pressure is usually a deficient supply of the hydraulic fluid to the pump. This can be caused by incorrect priming, a lack of hydraulic fluid or dirt in the suction filter. Check the indicated points to guarantee correct operation.

#### 3. Noise

A noise similar to screeching is a symptom of cavitation. The noise is normal if it occurs when starting and lasts for approximately thirty seconds.

If the noise continues, stop the machine to protect the hydraulic pump and make sure that the connectors are tight and that the pump has been correctly primed.

Another possible cause of noises in the pump is excessive temperature in the hydraulic oil. Make sure the oil supply is correct, and, if necessary, improve the ventilation to allow better dissipation of the heat in the hydraulic tank.

## MAINTENANCE

To achieve maximum output from the **evolution G-35 H** unit, certain daily or regular maintenance operations are needed.



***To prevent possible bodily harm caused by incorrect handling of the raw materials and solvents used in the process, carefully read the safety information provided by your supplier.***

***Deal with the waste created according to current regulations.***



***Disconnect the unit from the power supply before carrying out any operation inside the electrical console.***

***The electrical maintenance of the machine must only be performed by a qualified electrician.***



***To avoid damage caused by the impact of pressurized fluids, do not open any connection or perform maintenance work on components subject to pressure until the pressures have been completely eliminated.***

***Use suitable protection when operating, maintaining or remaining in the operating area of the unit. This includes, but is not limited to, the use of face masks, protective goggles, gloves, shoes and safety clothing.***



***The unit includes components that reach temperature that are liable to cause burns. The hot parts of the unit must not be handled until they have cooled.***



***To prevent serious harm by crushing or loss of limbs, do not work with the unit without the safety duly installed on all moving parts. Make sure that all of the safety protections are correctly fitted after all repair or maintenance work.***





## Heaters

**WARNING!** Before performing any maintenance work, make sure all of the pushbuttons are off, that the general switch is in shutdown position and that the unit is disconnected from the power supply source. Never handle the inside of the control panel with the unit connected to the power supply. The heater is a component that reaches high temperatures; wait until it has cooled before handling.

### 1. Heating Elements

To replace a faulty element, proceed as follows:

- a) Depressurise the unit, disconnect it from the power supply and remove the cover on the heater.
- b) Disconnect the element from the terminal block and with an appropriate spanner, loosen the element and remove it from its housing. Inspect the element; it must be smooth and shiny in appearance. If it is blackened or has material adhered, replace it.
- c) Check the new element with a tester: the reading of the value of the resistance must be as shown in Table 2 on pag.32.
- d) Apply Teflon or sealing paste to the thread and assemble the element into its housing.
- e) Reconnect the wires to the terminal block; make sure the connection is in parallel and fit the heater cover.

**NB:** If the element that has to be replaced is the one in contact with the temperature probe, first remove the probe.

### 2. Temperature

The temperature probe is fixed to the connector with a ferule and a torque nut. Once inserted in its housing, the ferule forms to the probe and does not allow it to be relocated or moved. The location of the probe is very important and must be done correctly before fitting the torque nut.

- a) Depressurise the unit and disconnect it from the power supply. Check the torque of the body of the connector inserted in the heater to prevent leaks.
- b) Assemble the heating element.
- c) Insert the torque nut and the ferule in the probe and insert this in the connector body until it comes into positive physical contact with the heating element. Make sure the spring does not prevent the probe from making contact with the resistance.
- d) Fix the probe in place and tighten the torque nut.



## Hydraulic unit

**WARNING!** Before performing any maintenance work, make sure all of the pushbuttons are off, that the general switch is in shutdown position and that the unit is disconnected from the power supply. Never handle the inside of the control panel with the unit connected to the power supply. The hydraulic unit is a component that works under pressure; do not open any connection or carry out maintenance work on components subject to pressure until all of the pressures have been completely eliminated.

The hydraulic unit must be serviced each year as indicated below:

- a) Depressurise the unit and disconnect it from the power supply. Clean the hydraulic tank lid to prevent foreign bodies from falling into the tank when the lid is removed.
- b) Remove the suction pipe from the connection with the hydraulic pump and the tank lid.
- c) Separate the lid and the suction pipe from the hydraulic tank. Inspect the bottom of the tank for sediments. If there is sediment present, the tank must be emptied completely and the bottom must be cleaned, eliminating all the sediment and filling it once more with new hydraulic fluid.
- d) Clean the suction pipe and its connections.
- e) Replace the oil suction filter.
- f) Fit the suction pipe in the tank and fit the lid. Connect the suction pipe to the hydraulic pump.
- g) Check that the hydraulic pump is full of fluid and proceed with the normal operation.



## Metering pumps

**WARNING!** Before proceeding with maintenance works, make sure that all push buttons are switched off, the general switch is in the off position, and the Unit is unplugged from the power supply. Never handle the control panel interior while the Unit is plugged into the electricity grid. Dosing pumps are components that work under pressure, do not open any connections or perform any repair or maintenance work on components submitted to pressure until all pressures have been completely released.

When the pump works properly, it is not uncommon for a small amount of resin to filter through the joints and reach the visible part of the pump axis. Periodically inspect the axis and clean the residue when dosing pumps are stationary and the machine is switched off.

Disassemble and clean the dosing pumps annually, despite no obvious signs of leaks. Use this time to completely replace the joints and bearings given that, if you reassemble an element that does not seem damaged, it can cause premature wear in the remaining components (the NR-00065 Components Manual includes the joint kits that correspond to each pump model and size). Pump distribution bases must also be inspected, checking that the ball valves show no signs of wear, dents or marks that affect the pump's proper operation.

Perform a daily inspection of the Isocyanate pump lubrication bowl and check the condition of the DOTP plasticiser oil it contains. Replace the oil when you observe colour changes or when it shows signs of solidification. If this circumstance persists, replace the isocyanate pump joints using the corresponding kit.

In cases where the machine is submitted to large workloads or special work conditions, disassemble, clean and replace the dosing pump joints every six months.

Inspect rods, pistons and inside the sleeves for marks or scratches that may cause leaks or premature damage to the joints.

Only qualified personnel will be authorised to replace dosing pump joints, since they have the required expertise to that effect.

**NOTE:** Three special tools can be used to simplify the seal assembly. Tools A and B to insert the shaft seal into the seal housing and tool C for the packing retainer flange assembly insertion through the shaft.

**Table 3. Tools for shaft seal assembly**

	Tool (A)	Tool (B)	Tool (C)
			
#0.80 Pump	HT-00124	HT-00125	HT-00036
#1.20 Pump			HT-00035

### Seals assembly

PISTON SEAL

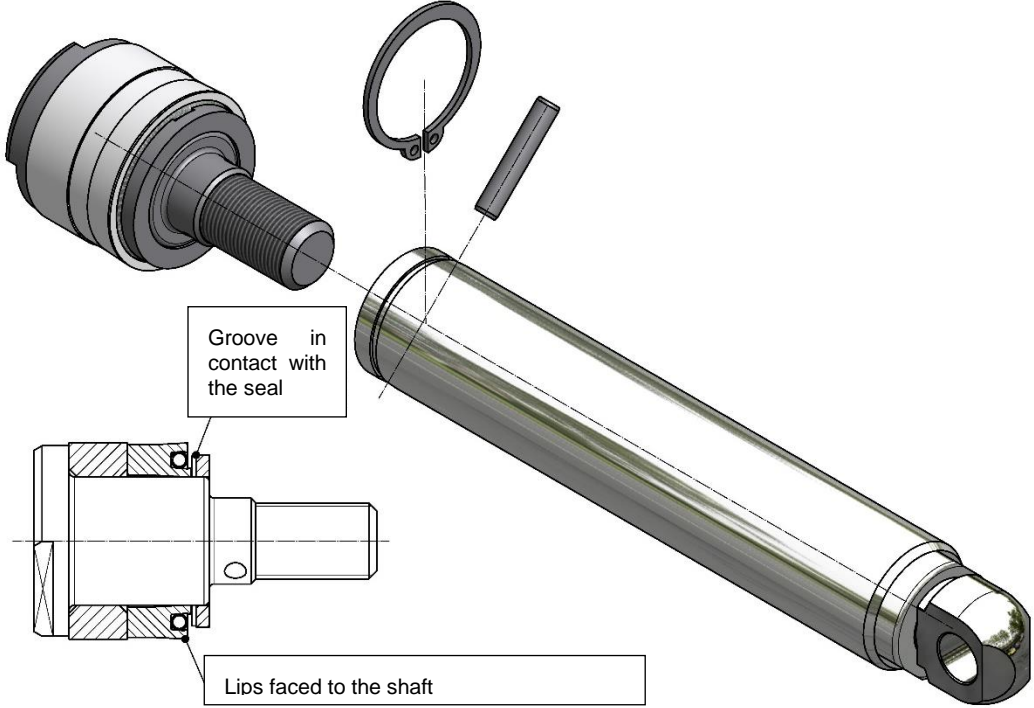

The diagram illustrates the assembly of a piston seal. It shows a piston shaft with a groove for the seal. A plunger assembly is being inserted into the shaft. A spring pin is inserted into the shaft to secure the plunger. A snap ring is inserted into the groove to secure the seal. Labels indicate 'Groove in contact with the seal' and 'Lips faced to the shaft'.

Insert the piston bearing, seal and washer into the piston shaft. Face the lips of the seal towards the end of the shaft. Face the grooves of the washer towards the seal.	Thread the plunger assembly onto the shaft as far as it will go (the pin holes in the shaft and plunger should line up).	Insert the spring pin so that it is recessed in the groove of the shaft. Insert the snap ring into the groove.
--	--	---

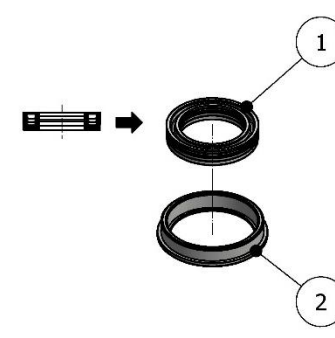
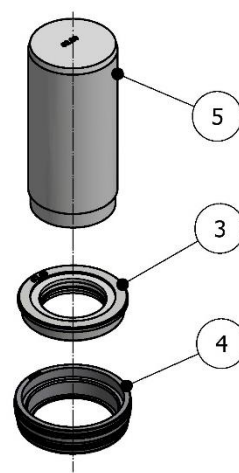
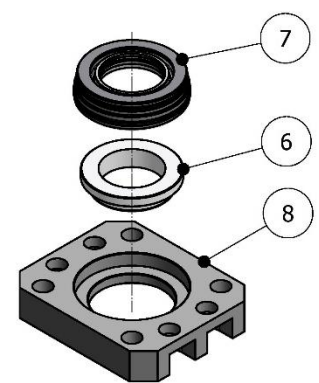
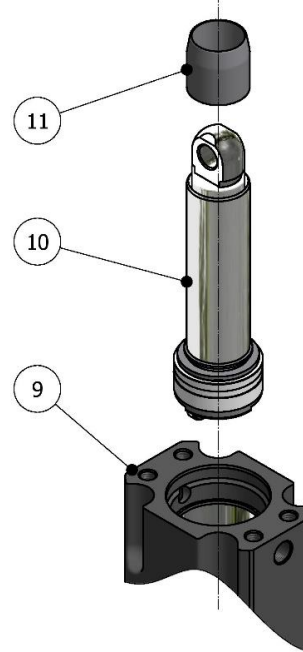
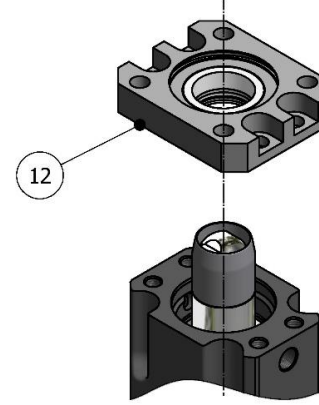
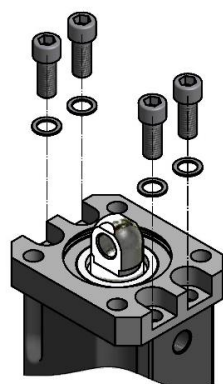
SHAFT SEAL		
		
<p>Insert the seal (1) into Tool A (2). Make sure that the lips are facing upwards.</p>	<p>Place tool A with the seal (3) inside the seal housing (4). With tool B (5) push the seal until it stops against the seal housing (4).</p>	<p>Place the shaft bearing (6) and the seal housing along with its corresponding O-rings (7) on the packing retainer flange (8).</p>
		
<p>Insert the shaft assembly (10) into the pump body (9) and place the tool C (11) on the tip of the shaft.</p>	<p>Mount the packing retainer flange assembly with all components assembled (12) on the front face of the pump. The shaft bearing should be visible from the outside.</p>	<p>Remove tool C and fix the packing retainer flange with its corresponding screws.</p>



## **Inlet supply filters**

The filter bodies have a filter screen that prevents solid particles from entering the unit. Inspect the filters each day as part of the machine start-up, and clean them. Replace the filter screen if necessary.

Isocyanate is a product that crystallises with ambient moisture or freezing. If the storage and transfer is correct and the operating procedures are respected, the risk of contamination of the Isocyanate filter will be minimised.

***NB: Clean the Isocyanate inlet filter before the daily start-up; it should not be cleaned after the machine has been stopped for the day. Immediate use after cleaning the filter reduces the risk of moisture contamination or contamination through the reaction with the solvent used in the cleaning operation.***

To check the product inlet filters, proceed as follows:

- a) Disconnect the unit from the power supply and close the inlet ball valve from the filter you wish to check.
- b) Place a suitable vessel under the filter to collect the product coming out on removal. Carefully loosen the filter stopper to allow the product to be emptied into the vessel below. Completely unscrew the stopper.
- c) Remove the seal, the spring and the mesh and clean it all with the solvent used for cleaning the gun. Dry it all and check that the mesh is not obstructed. The holes in the mesh must be completely free. Replace the mesh if more than 10% of the surface is obstructed.
- d) Refit the mesh, the spring and the seal. Screw on the stopper.
- e) Open the product entry valve of the filter, make sure there are no leaks and proceed with the normal operation.



## *Isocyanate pump lubrication system*

Each day, inspect the lube reservoir of the Isocyanate pump and check the condition of the DOTP. Replace the oil when it shows changes in color or signs of solidification.

Oil solidification is the result of the absorption of moisture and the maintenance interval will depend on the working conditions. The closed circuit system reduces contamination.

Oil discoloration is due to the small film of Isocyanate that lies on the pump shaft during the pumping operation. If the gaskets and the seals are in a good condition, the plasticizer will not have to be changed so frequently.

To replace the plasticizer, proceed as follows:

- a) Project the gun until the Isocyanate metering pump is placed on the right hand side. Press the NORMAL key to interrupt the working cycle. The pushbutton led will go out.
- b) Press the MOTOR and POWER CONTROL keys and turn the general switch OFF. Disconnect the machine from the power supply.
- c) Remove the tank from the support, unscrew the lid, remove the non-return valve of the suction hose, empty the contaminated plasticizer in a suitable vessel and refit the non-return valve in the suction hose.
- d) Clean the tank, fill it with DOTP, screw on the lid and refit the tank in the support. The system is auto-suction and does not need priming.



## CONTENT

<b>Warranty</b>	<b>2</b>
<b>Safety and Handling</b>	<b>3</b>
<b>Characteristics</b>	<b>6</b>
Principal Heating System	6
Hose Heating System	6
Double Acting Opposed Piston Metering Pumps	6
<b>Technical Specifications</b>	<b>7</b>
Electrical	7
Mechanical	7
Acoustics	7
<b>General Description</b>	<b>8</b>
<b>Control Panel</b>	<b>12</b>
<b>Alarms</b>	<b>17</b>
<b>Method of Threaded Union of the Hoses</b>	<b>19</b>
<b>Installation</b>	<b>20</b>
<b>Start - UP Procedures</b>	<b>26</b>
<b>Shutdown proedures</b>	<b>27</b>
<b>Cleaning</b>	<b>28</b>
<b>long term shutdown procedures</b>	<b>29</b>
<b>Troubleshooting</b>	<b>30</b>
Heaters	31
Hose heating	34
Metering pumps	36
Hydraulic unit	39
<b>Maintenance</b>	<b>40</b>
Heaters	41
Hydraulic unit	42
Metering pumps	43
Seals assembly	44
Inlet supply filters	46
Isocyanate pump lubrication system	47
<b>Content</b>	<b>48</b>
<b>List Of Illustrations</b>	<b>49</b>





List Of Tables	49
----------------	----

## LIST OF ILLUSTRATIONS

Figure 1. General Description.	8
Figure 2. Control Panel	12
Figure 3. Method of union of the Hoses	22

## LIST OF TABLES

Table 1. Tightening Threaded Joints	19
Table 2. Elements Values List	32
Table 3. Tools for shaft seal assembly	44